



**INSTRUCTION MANUAL
DPS (DIGITAL POSITION SYSTEM)
QT series (General Description)**



Instruction, installation and
maintenance manual





INSTRUCTION MANUAL DPS (DIGITAL POSITION SYSTEM) QT series (General Description)



INDEX

1.0	Description	3
1.1	System description	3
1.1.1	Servo-Valve (S)	3
1.1.2	Digital Controller (C)	3
1.1.3	Magnetostrictive Position Feedback Probe (Z)	3
1.1.4	Actuator with DPS series QT Interface	4
1.1.5	Umbilical Cable (UC)	4
1.1.6	Fail-Mode Solenoid Valve (EV)	4
1.1.7	Fail-Mode pneumatic valves (3-way or 2-way valve for CV30 and CV9 model)	4
1.2	Specification and options	4
1.2.1	Power Supply	4
1.2.2	Temperature Rating	4
1.2.3	Air Supply	4
1.2.4	Specifications	5
2.0	General safety instructions	5
2.1	Installation	5
2.2	Maintenance	5



INSTRUCTION MANUAL DPS (DIGITAL POSITION SYSTEM) QT series (General Description)



1.0 DESCRIPTION



The DPS series QT controller is a high-capacity, high-precision digital-pneumatic valve controller that replaces conventional positioner and volume booster assemblies. The DPS series QT has several advanced control and diagnostic features. There are two different models, DPS series QT (Cv30) and DPS series QT (Cv9).

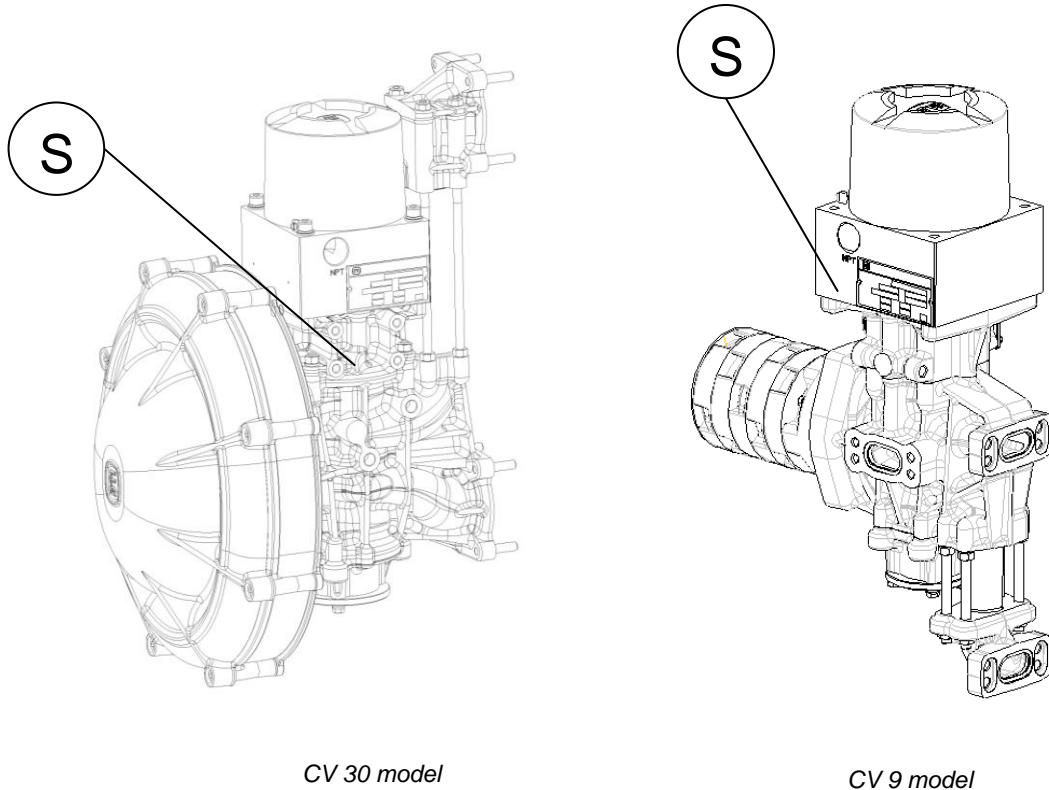

1.1 SYSTEM DESCRIPTION

The DPS series QT components are:

1.1.1 Servo-Valve (S)

A high-capacity Servo-Valve is used to position the actuator. The Servo-Valve spool is positioned by a stepper-motor. This arrangement provides very fine and accurate control of actuator position. This assembly can be mounted directly to the actuator using manifolds, or remote-mounted. There are two Servo-Valve models, DPS series QT (Cv30) and DPS series QT (CV9).

Pressure transducers within the Servo-Valve manifold measure the pressure of the air supply and the pressure above and below the actuator piston. The stepper-motor has an integral spool-position feedback device. Standard Fail Modules for Fail-Open, Fail-Closed and Fail-In Place are available for all models.

1.1.2 Digital Controller (C)

The Digital Controller provides closed-loop control of valve position based upon input signal, valve position feedback, spool position feedback and stepper-motor control. The Digital Controller is housed in an enclosure which also features a power supply, terminal blocks, display and local controls. The Digital Controller can be mounted directly to the actuator or remote-mounted.

1.1.3 Magnetostrictive Position Feedback Probe (Z)

Valve position feedback is provided by a magneto-restrictive probe located in centre of the actuator top cap.



INSTRUCTION MANUAL DPS (DIGITAL POSITION SYSTEM) QT series (General Description)



- 1.1.4 Actuator with DPS series QT Interface
The Cv30 uses a special STI actuator (A), with special end plates with larger ports. The Cv30 and Cv9 use a standard STI Actuator, modified to accommodate the DPS series QT components. The actuator shaft is gun-drilled to accommodate the feedback probe.
- 1.1.5 Umbilical Cable (UC)
The Digital Controller and Servo-Valve / Fail Module are connected with a cable which transmits signal and power.
- 1.1.6 Fail-Mode Solenoid Valve (EV)
DPS series QT uses a continuously-energized, normally-closed 24Vdc solenoid valve to initiate fail mode. This Solenoid Valve is tripped by the Controller, which can initiate fail-mode on loss of air, power, signal.
- 1.1.7 Fail-Mode pneumatic valves (3way or 2way valve for CV 30 and CV 9 model)
The fail mode is made by those pneumatic valves that are piloted by the solenoid valve (EV).

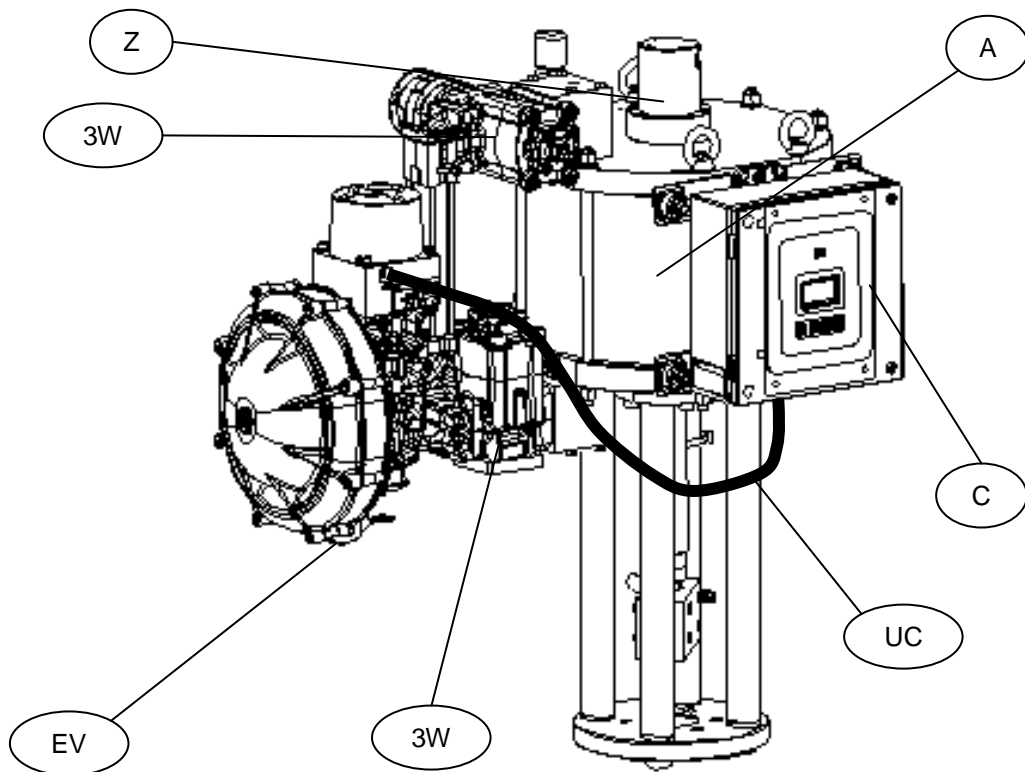

QuickTrak™ CV 30 and actuator assembly

1.2 SPECIFICATION AND OPTIONS



- 1.2.1 Power Supply
The DPS series QT is a "4 wire" system; it requires a power supply independent of control signal. The power supply can be 120Vac, 240Vac, 110Vdc, 48Vdc or 24Vdc.
- 1.2.2 Temperature Rating
The standard working temperature for both controller and step motor assembly is -20°C to +70°C. For cold (-20 to -40°C) or for hot environment (+70 to 100°C), the Servo-Valve and the Digital Controller require a heater or a cooling system or they must be remote-mounted in a mild environment.
- 1.2.3 Air Supply
The air supply must be clean and dry, and should comply with ISA 7.3, para. 4.1: The dewpoint at

line pressure shall be at least 10 C (18 F) below the minimum ambient temperature. A 5 micron filter regulator will be supplied.

1.2.4 Specifications

	<i>Standard</i>	<i>Option</i>
<i>Input Signal / Position Feedback</i>	4-20 mA; Hart protocol	
<i>Maximum power consumption</i>	95W	
<i>Power Supply Module</i>	120 Vac ±10% 50-60Hz ±5% 240 Vac ±10% 50-60Hz ±5% 110Vdc ±10% 1A 48Vdc ±10% 3A 24Vdc ±10% 5A	
<i>Servo-Valve, Mounting</i>	Actuator	Remote
<i>Digital Controller, Mounting</i>	Actuator	Remote
<i>Digital Controller, Cable Length</i>	6.0 ft (~ 1.8 m)	100 ft (~ 30 m)
<i>Electrical Classification</i>	EMC	
<i>Certification for Ordinary Location</i>	IP66; UL ordinary location; NEMA4X	
<i>Certification for Hazardous Location</i>	Ex d IIC Tx Gb for motor enclosure Ex d IIB T6 Gb for controller enclosure	
<i>Temperature Rating</i>	-4 to 158 F (-20°C to 70 °C)	-40 to 212 F (-40°C to 100 °C)
<i>Air supply</i>	60 to 100 psig (4 to 7 barg)	

2. GENERAL SAFETY INSTRUCTIONS

The non-observation of the following safety instructions and of the instruction manuals can result in with serious injury.

2.1 INSTALLATION



- Must be done by qualified person trained to operate.
- A ground tap is necessary.
- The electrical and pneumatic connections must be done according to the diagram and label.
- The supply circuit must be protected in case of current exceeding the limit fixed.
- The equipment must be provided with cable entries and filler plugs certified according to the required certification.
- The actuator must be installed and used according to the project design specification.
- The fluid must be chemically compatible with the used gaskets and lubricant.
- The supply circuits must be protect in case of current exceeding the limits fixed The user has to ensure prior to start up and during operation that the pressure transducers are correctly fixed inside the enclosure all the time.
- The rated values for pressure transducer must be observed.



2.2 MAINTENANCE

- Must be done by qualified person.
- Cleaning must be done with a humid cloth.
- Greases and oils must be used according to the manufacturer's instructions, however their flammability point must be > 140°C.

Information in this manual is protected by copyright. All rights are reserved. No part of this manual and relevant mentioned and/or enclosed documentation may be reproduced without written authorization by **STI S.r.l.**

STI S.r.l. is not responsible for possible damage to people, equipment or data which might arise from incorrect use of the product to which the manual is referred.

Information in this document may be modified at any time without notice.



INSTRUCTION MANUAL DPS (DIGITAL POSITION SYSTEM) QT series (Software)



User manual

Referred to:

HC12 software revision starting from 4.01
DSP software revision starting from 4.01
RC software revision starting from 4.01
PLD software revision starting from 1.04.00.00

Starting from release 4.01 new functions are available:

<i>SD CARD</i>	<i>see chapter.... 3.5</i>
<i>SOV CONFIGURATION</i>	<i>see chapter.... 3.7.1</i>
<i>PROBE FAIL CONFIGURATION</i>	<i>see chapter.... 3.7.6</i>
<i>DIAGNOSTIC</i>	<i>see chapter.... 3.11</i>
<i>USER POSITION</i>	<i>see chapter.... 3.12.1</i>
<i>FULL SPEED</i>	<i>see chapter.... 3.12.6.4</i>
<i>ON MODE</i>	<i>see chapter.... 3.12.6.5</i>
<i>CUT OFF SPEED CONTROL</i>	<i>see chapter.... 3.12.7.3</i>
<i>TRIPS DETECTION TIME</i>	<i>see chapter.... 3.12.7.4</i>



INSTRUCTION MANUAL DPS (DIGITAL POSITION SYSTEM) QT series (Software)



INDEX

1	DESCRIPTION	4
1.1	CONTROLLER SWITCH ON / OFF	5
2	SOFTWARE INSTALLATION	6
2.1	REMOTE CONTROL SOFTWARE	6
2.2	CONTROLLER SOFTWARE	8
2.2.1	DSP software installation	9
2.2.2	HC12 software installation.....	10
3	DESCRIPTION OF THE MENU	13
3.1	MAIN.....	15
3.1.1	ERROR PAGE.....	15
3.1.2	USER ACCESS PAGE	17
3.2	SYSTEM INFO	19
3.3	SYSTEM SET UP	20
3.3.1	TRAVEL CONTROL	21
3.3.2	TUNING.....	24
3.3.3	INPUT CHARACTERISTIC	27
3.3.4	INPUTS	30
3.3.5	OUTPUTS	33
3.4	CALIBRATION	38
3.5	SD CARD	40
3.6	COMMAND MODE	41
3.6.1	SERVICE OUT / IN.....	41
3.6.2	MANUAL.....	42
3.7	FAIL & TRIP SETTING.....	44
3.7.1	SOV CONFIGURATION.....	45
3.7.2	POSITION EXCESS FAIL MODE.....	47
3.7.3	POWER FAIL MODE	51
3.7.4	SIGNAL FAIL MODE	55
3.7.5	PRESSURE FAIL MODE.....	59
3.7.6	PROBE FAIL	61
3.7.7	TRIPS MODE (for trip 1, 2, 3, 4).....	62
3.8	GENERAL SETTING	66
3.8.1	MEASUREMENTS UNITS.....	66
3.8.2	LANGUAGE.....	67
3.8.3	DATE AND TIME	67
3.8.4	PASSWORD	68
3.8.5	CONTRAST.....	69
3.9	SYSTEM DATA	70
3.10	COMMUNICATION.....	71
3.10.1	HART TAG	71
3.10.2	MESSAGE.....	72
3.10.3	DESCRIPTOR.....	73



INSTRUCTION MANUAL DPS (DIGITAL POSITION SYSTEM) QT series (Software)



3.10.4	DATE.....	74
3.10.5	POLLING ADDRESS.....	74
3.10.6	DEVICE ID	76
3.11	DIAGNOSTIC	77
3.11.1	PERM. TIME.....	80
3.11.2	dP UP-DOWN	81
3.11.3	ERROR STAT	82
3.11.4	CALIB STAT	84
3.11.5	OUT SVC STAT	85
3.11.6	IN SVC STAT	85
3.11.7	STAT FREQ	86
3.11.8	EVENT LOG.....	87
3.12	ADVANCED	88
3.12.1	PROBE.....	89
3.12.2	MOTOR	91
3.12.3	SOV.....	93
3.12.4	4-20 mA.....	94
3.12.5	PRESSURE.....	96
3.12.6	GENERAL	100
3.12.7	REMOTE CONTROL SW >>> STI PAGE >>> GENERAL TAG.....	104
3.13	REMOTE CONTROL SW >>> TOOLBAR OPTIONS	106
3.13.1	FILE MENU	106
3.13.2	DEVICE MENU.....	106
3.13.3	PASSWORD MENU.....	107
3.13.4	DATA RECORDING MENU.....	107
3.13.5	INFO MENU	107
4	GRAPH	108
5	TROUBLE SHOOTING	111



INSTRUCTION MANUAL DPS (DIGITAL POSITION SYSTEM) QT series (Software)



1 DESCRIPTION

The QuickTrak III controller can be locally operated by:

- a local device monitor and 4-key keyboard located under the monitor;

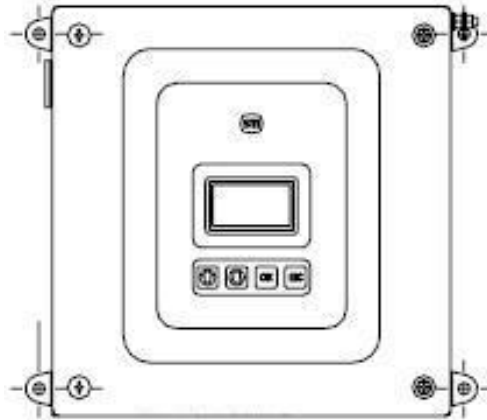

- via HART hand-held terminal;
- by a remote control panel running on a laptop connected to the controller by an RS 232 serial interface or via HART modem.



CAUTION: In order to prevent any system reaction due to an unauthorized use or accidental contact of the keypad, the system should always be left on the MAIN page. After 5 minutes the system is in stand-by, it returns automatically to the MAIN page.



WARNING: If communication mode via RS-232 serial interface is required, be careful that the control panel can be opened only when the units in a no hazardous area.



INSTRUCTION MANUAL DPS (DIGITAL POSITION SYSTEM) QT series (Software)



1.1 CONTROLLER SWITCH ON/OFF

To turn on / off the controller, switch on /off the power switch inside the controller.

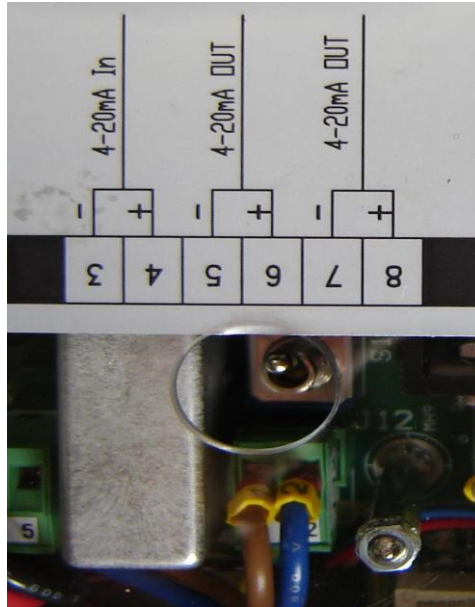



INSTRUCTION MANUAL DPS (DIGITAL POSITION SYSTEM) QT series (Software)



2 SOFTWARE INSTALLATION

2.1 REMOTE CONTROL SOFTWARE

If a remote PC control via RS 232 is required, a management software should be installed on the laptop. The minimum system requirements are: MS-Windows-98, Windows-NT 4.0, Service Pack 5 or 6a, Windows 2000 or Windows XP.

To install the software:

- make sure that the minimum hardware requirements are met;
- start Windows;
- shut down all running programs;
- insert the provided CD;
- install routine should start automatically otherwise activate the program "*SetupQT3_v401.exe*";
- follow the instruction;
- insert the password. The standard software manufacturer default password is: **1 2 3 4 5**;
- download the parameters to test the communication.



CAUTION: Do not attempt to operate the process valve in the plant without performing the calibration, as an unpredictable performance may result. A detailed description of the calibration process and the required steps are provided elsewhere in this manual.

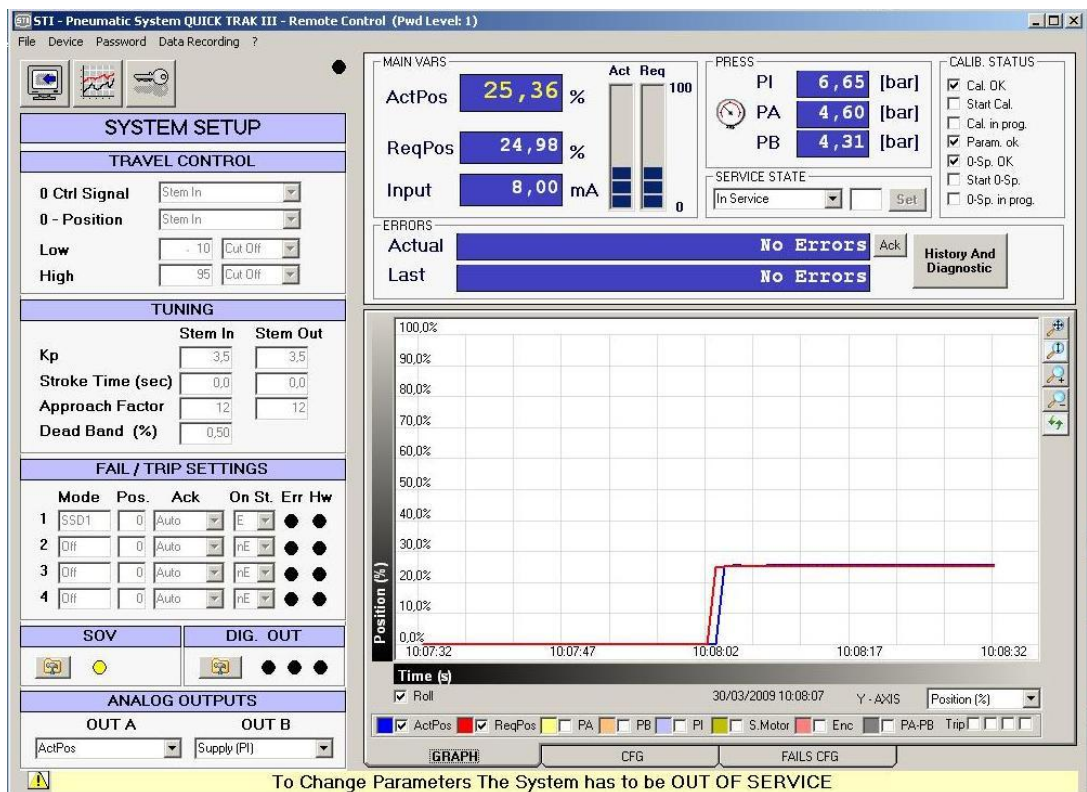

The parameters download is available in the main command line (pull-down device menu).





INSTRUCTION MANUAL DPS (DIGITAL POSITION SYSTEM) QT series (Software)



At the end of the download phase the configuration parameters fields will be update.

STI - Pneumatic System QUICK TRAK III - Remote Control (Pwd Level: 0)

File Device Password Data Recording ?

MAIN VARS
ActPos **25,44** %
ReqPos **24,97** %
Input **8,00** mA

PRESS
PI **6,67** [bar]
PA **4,38** [bar]
PB **4,16** [bar]

CALIB. STATUS
 Cal. OK
 Start Cal.
 Cal. in prog.
 Param. ok
 0-Sp. OK
 Start 0-Sp.
 0-Sp. in prog.

SERVICE STATE
In Service [Set]

ERRORS
Actual **No Errors**
Last **No Errors**

GRAPH
Position (%) vs Time (s)
30/03/2009 10:17:27 Y-Axis Position (%)

To Change Parameters The System has to be OUT OF SERVICE



INSTRUCTION MANUAL DPS (DIGITAL POSITION SYSTEM) QT series (Software)



2.2 CONTROLLER SOFTWARE

The two software (DSP and HC12) are factory installed in the controller. For a new installation, a "Loader" program is necessary. It can be installed selecting "SETUP.exe" file from the supplied LOADER software cd. A shortcut should appear in the program selection of start menu. Select the "Loader" access program:

Program » Loader » Loader

Or select it directly:

C:\Program Files\STI s.r.l.\Loader\Loader.exe

The following window will appear:

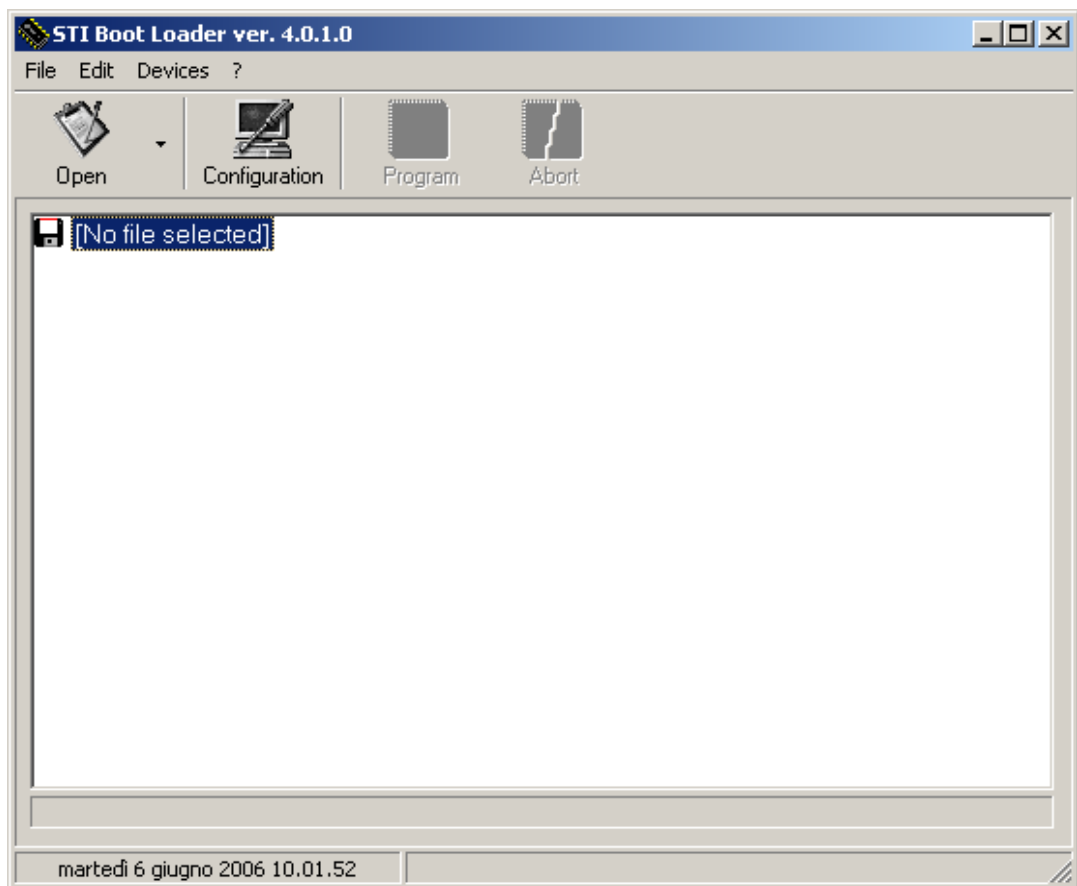

Configure the PC COM port selecting: "Configuration" from EDIT menu for both Texas (DSP) and Motorola (HC12).



INSTRUCTION MANUAL DPS (DIGITAL POSITION SYSTEM) QT series (Software)

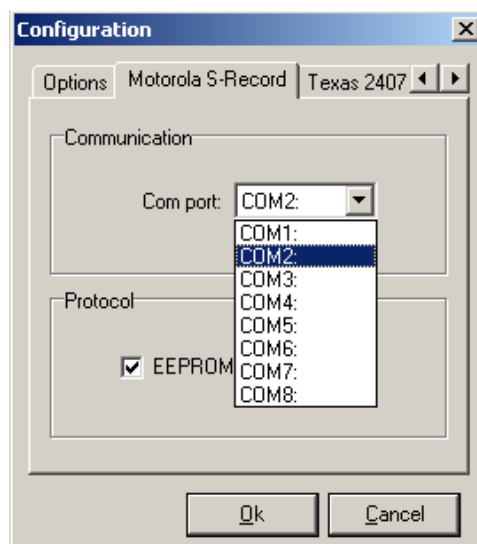
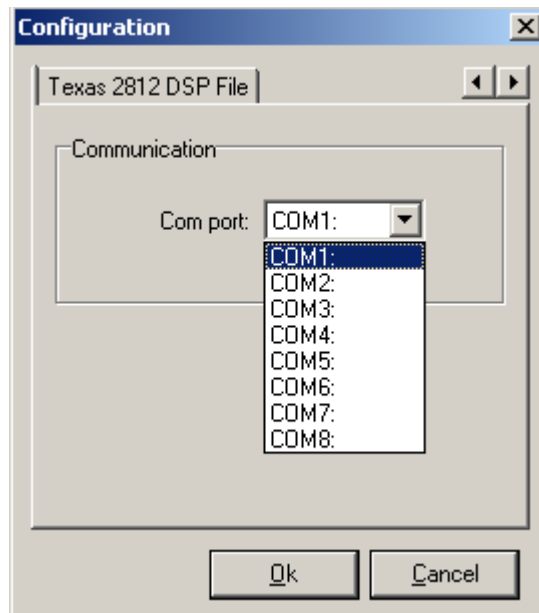

2.2.1 DSP software installation

Copy the DSP software to be installed to a folder on the laptop. File extension should be “.hex”. Perform the following steps on the QuickTrak III controller to prepare it for software loading.

- Turn off the controller by the main power switch.
- Change the switches SW5 as showed in SW Upgrade mode (see on the board).





INSTRUCTION MANUAL DPS (DIGITAL POSITION SYSTEM) QT series (Software)



- Attach the RS 232 9 pin cable to the J9 connection block (Com DSP).
- Launch the loader program as in §2.2.
- Select the down arrow next to the “OPEN” quick select button.



- Select “Texas DSP File”
- Locate the .HEX file, and select OPEN

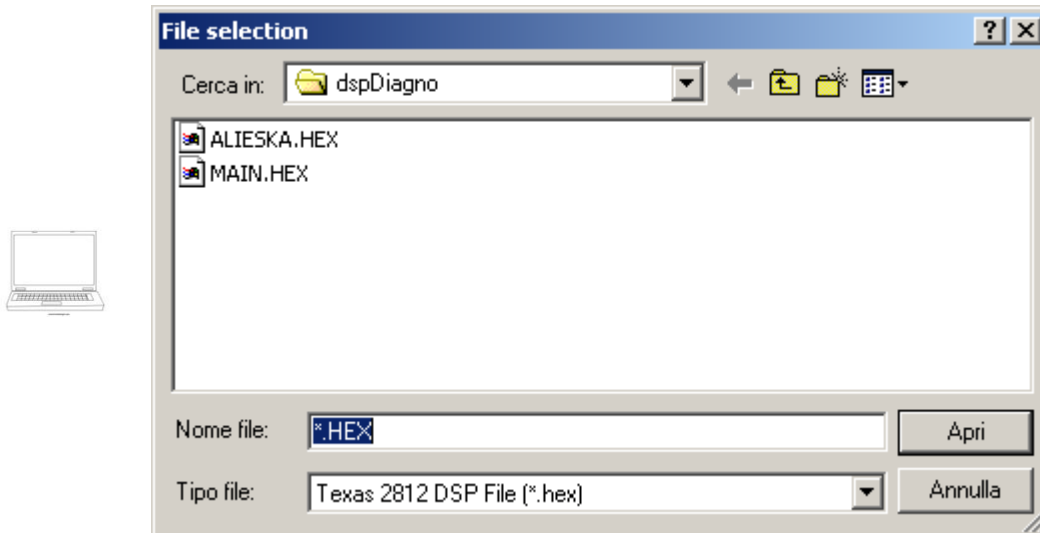

- Turn on the controller
- Select the “Program” quick select button



- The program should run to completion
- Upon completion select File » Exit
- Turn off the controller
- Change the switches SW5 as showed in Normal mode (see on the board).

2.2.2 HC12 software installation

Copy the HC12 software to be installed to a folder on the laptop. File extension should be “.s19”. Perform the following steps on the QuickTrak III controller to prepare it for software loading.

- Turn off the controller by the main power switch.
- Attach the RS 232 9 pin cable to the J11 connection block (COM μ P).



INSTRUCTION MANUAL DPS (DIGITAL POSITION SYSTEM) QT series (Software)

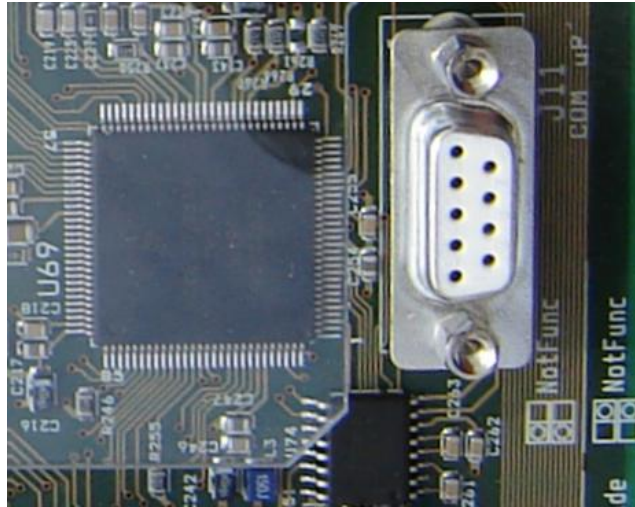

- Launch the loader program.
- Select the down arrow next to the “OPEN” quick select button and choose “Motorola S- Record”.

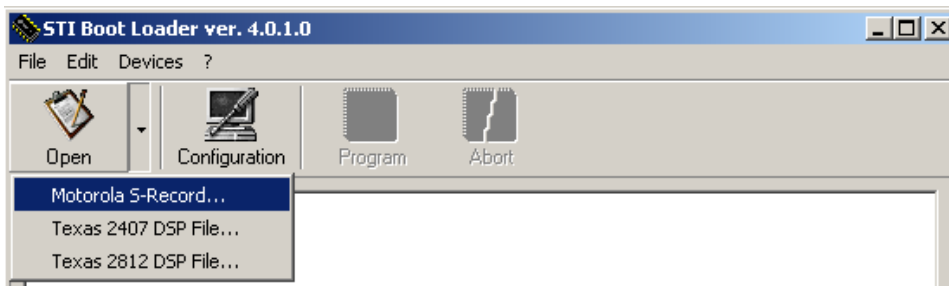

- Locate the .S19 file and select OPEN.

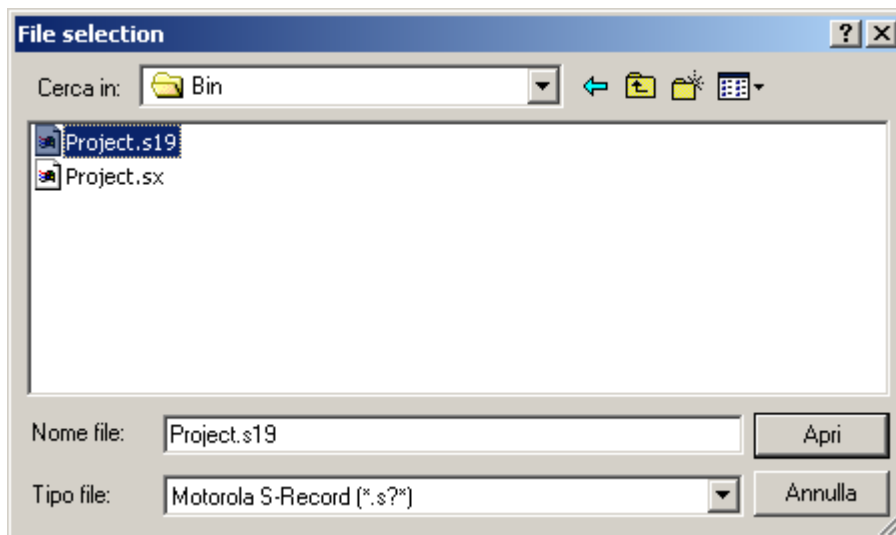

- Select the “Program” quick select button.
- Turn on the controller.
- The program should run to completion.



INSTRUCTION MANUAL DPS (DIGITAL POSITION SYSTEM) QT series (Software)

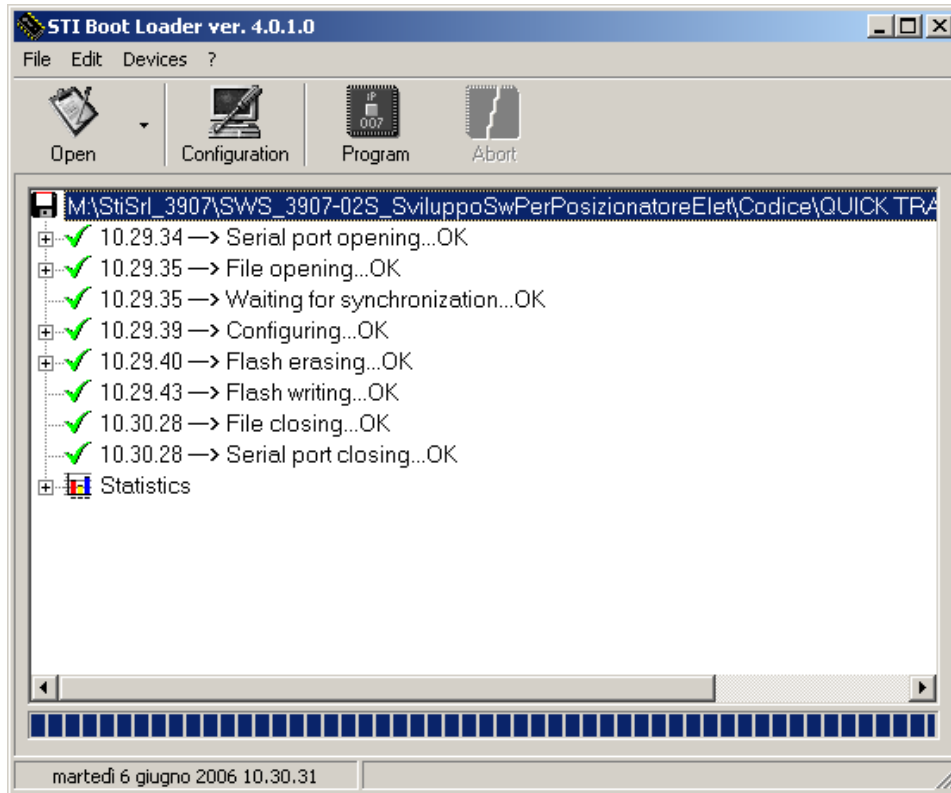

- Upon completion select File » Exit.
- Turn off the controller.



INSTRUCTION MANUAL DPS (DIGITAL POSITION SYSTEM) QT series (Software)



3 DESCRIPTION OF THE MENU

An easy interface for the user is provided for the management and configuration of the system. The interface is performed by the following devices: one main menu, many submenus and linked pages.

The structure of the menu is displayed in the following picture:



- I. MAIN**
- II. SYSTEM INFO**
- III. SYSTEM SET UP**
 - III.1 TRAVEL CONTROL
 - III.2 TUNING
 - III.3 INPUT CHAR.
 - III.4 INPUTS
 - III.5 OUTPUTS
 - III.6 RESET COMMAND
- IV. CALIBRATION**
 - IV.1 PROBE CONSTANT
 - IV.2 CALIBRATION
 - IV.3 SYSTEM CALIBRATED
- V. COMMAND MODE**
 - V.1 SERVICE OUT / IN
 - V.2 MANUAL
- VI. FAIL & TRIP SETTING**
 - VI.1 SOV CONFIGURATION
 - VI.2 POSITION EXCESS FAIL MODE
 - VI.3 POWER FAIL MODE
 - VI.4 SIGNAL FAIL MODE
 - VI.5 PRESSURE FAIL MODE
 - VI.6 MODE FOR TRIP1
 - VI.7 MODE FOR TRIP2
 - VI.8 MODE FOR TRIP3
 - VI.9 MODE FOR TRIP4
- VII. GENERAL SETTING**
 - VII.1 MEASUREMENT UNITS MET / IMP
 - VII.2 LANGUAGE
 - VII.3 DATE & TIME
 - VII.4 PASSWORD
 - VII.5 CONTRAST
- VIII. SYSTEM DATA**
 - VIII.1 TE
 - VIII.2 VI
- IX. COMMUNICATION**
 - IX.1 HART PROTOCOL 6.0
- X. DIAGNOSTIC**
 - X.1 STROKE KM
 - X.2 IN SVC HOURS
 - X.3 MIN TEMP.
 - X.4 MAX TEMP.
 - X.5 AVER.TEMP.
 - X.6 PERM.TIME
 - X.7 dP UP-DOWN
 - X.8 ERROR STAT
 - X.9 CALIB STAT
 - X.10 OUT SVC STAT



INSTRUCTION MANUAL DPS (DIGITAL POSITION SYSTEM) QT series (Software)



X.11 IN SVC STAT

X.12 STAT FREQ

XI. ADVANCED

XI.1 DIAGNOSTIC DATA

XI.2 PROBE TYPE

XI.3 INTEGRAL

XI.4 PROP.GAIN MODE

XI.5 PROP.BAND GAIN

XI.6 PART NUMBER

XI.7 PASSWORD

XI.8 SET AS DEFAULT

XI.9 RESET STAT

XI.10 ERASE CALIB

XI.11 STAT DEBUG

XI.12 HART DEBUG

XI.13 PRESS.CALIB

XI.14 MOTOR TEST

XI.15 STEP MOTOR

XI.16 GEOMETRIC 0

XI.17 SPOOL LIMIT

The 4 keys provided (↑, ↓, OK, ESC) for the menus control, have the following function:

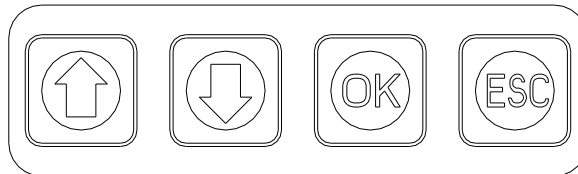

Key ↑ allows to shift on the option immediately preceding the one currently selected, enabling the menu shift in the counterclockwise direction up to the reaching of the first option.

Key ↓ allows to shift on the option immediately following the one currently selected, enabling the menu shift in the clockwise direction up to the reaching of the limit given by the last option.

the **OK** key confirms the option currently selected and activates the correspondent operation.

The **ESC** key (when enabled) allows to return to the previous menu.

The enabled keys are showed in reverse to help the operator's use of the interface, while the disabled keys are not pointed out.

3.1 MAIN

OK			MAIN
	ERR		To display the error page
	ESC		To display the user access page

The main page is displayed at the end of the device start up or by the operator's request. It has the following format on the controller display:

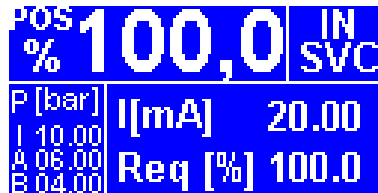

Selecting the MAIN page, the following main system information is displayed on the LCD monitor:

- OUT SVC or IN SVC
System service state (out of service or in service)
- SUPPLY
Supply pressure (at the servo valve inlet)
- PA
Pressure in the first chamber (servo valve output port)
- PB
Pressure in the second chamber (servo valve output port)
- INPUT
Inlet signal current [mA]
- REQPOS
Required Actuator Position [%]
- ACTPOS
Actuator Position [%]

The active buttons in this page are ERR and ESC; ERR to enter the system error page and ESC to go to the user access page.

If a PC connection is active, on the screen this information is shown in the STATUS window.

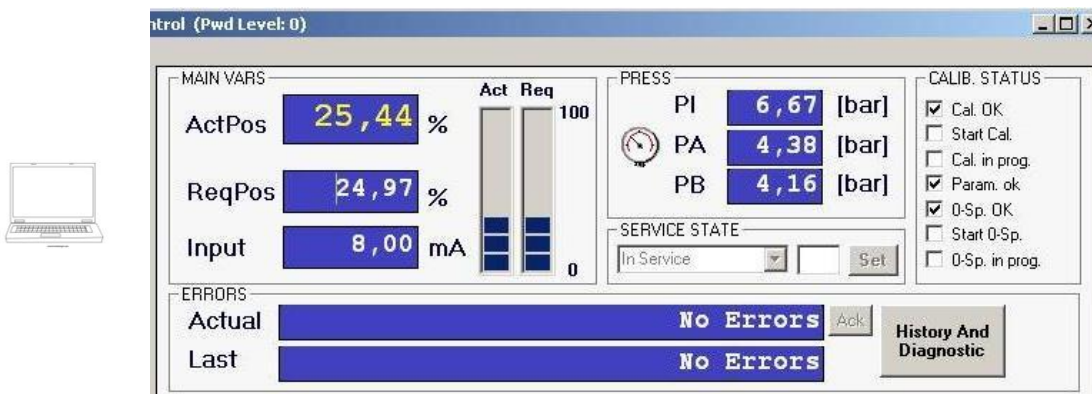

3.1.1 ERROR PAGE

OK			MAIN
	ERR		MAIN
		OK	To return to main menu
		ESC	To return to main menu



INSTRUCTION MANUAL DPS (DIGITAL POSITION SYSTEM) QT series (Software)



When ERR button is pushed from the main page the information referred to the present alarm (ERROR CONDITION) and the last detected alarm (LAST ERROR CONDITION) are showed.



ERROR CONDITION:
LAST ERROR CONDITION:
PRESS ESC/OK TO EXIT

In normal operation condition (no error or fail conditions), the error description showed is NONE.
The errors analyzed by the system are:

0	NONE	There are no active errors
1	TRIP 1	The trip 1 function is active
2	TRIP 2	The trip 2 function is active
3	TRIP 3	The trip 3 function is active
4	TRIP 4	The trip 4 function is active
5	PRESSURE FAIL	Pressure supply is lower than the selected pressure limit
6	LOW SIGNAL LIMIT FAIL	The inlet signal supply is lower than the selected low signal limit
7	HIGH SIGNAL LIMIT FAIL	The inlet signal supply is higher than the selected high signal limit
8	POSITION EXCESS ERROR	The difference between required and actual position, exceeds selected error values
9	POSITION EXCESS WARNING	The difference between required and actual position, exceeds selected warning values
10	PROBE ERROR	The probe is not working properly
11	LOW POWER LIMIT FAIL	The power is lower than the selected low power limit
12	HARD LIMITS ERROR	The actuator hard limits have been found invalid during the calibration routine
13	DSP TIMEOUT	There is no communication between HC12 and DSP cards
14	WATCH DOG ERROR	The watchdog circuit has detected a malfunction on the DSP card
15	HIGH POWER LIMIT FAIL	The power is higher than the selected high power limit
16	ERROR ON SOV1	Malfunction detected on SOV1 valve: valve is disconnected or circuit is interrupted (no current detected in the circuit)
17	ERROR ON SOV2	Malfunction detected on SOV2 valve: valve is disconnected or circuit is interrupted (no current detected in the circuit)
18	ERROR ON SOV3	Malfunction detected on SOV3 valve: valve is disconnected or circuit is interrupted (no current detected in the circuit)
19	DSP RESTART	The DSP has been improperly restarted
20	CALIBRATION ERASED	Warning message used in order to inform that a calibration parameters reset has been performed by the operator
21	Eeprom Error 0	Internal error on display electronic board
22	Eeprom Error 1	Internal error on display electronic board
23	HC12 RESTART	The HC12 has been improperly restarted
24	Eeprom Ext Error 0	Internal error on display electronic board
25	Eeprom Ext Error 1	Internal error on display electronic board
26	Probe Out of Range	The probe is reading -10% or 110%
27	EXC. FRICTION WARN	The "excess friction warn" message is

	EXC. FRICTION FAIL	displayed when 1000 steps are lost on a train of 5000 steps, while an "excess friction fail" message is shown when 4000 steps on a train of 5000 steps are lost.
28	INDEX1 NOT FOUND ERR	Encoder index is not found during calibration process.
29	INDEX2 NOT FOUND ERR	Encoder index is not found when the controller is switched on.
30	UNKNOWN	Unknown error received from DSP card
31	WAITING ACK	The system is waiting for the error acknowledgment, performed by the user
32	EXTERNAL SOV WARNING	Used only in case of trip connected to external SOV (and error mode for trip equal to EXTERN. SOV) Warning message used in order to inform that an external safety shut down valve has been activated
33	SYSTEM VERSION ERROR	The DSP SW version is not compatible with the HC12 SW version

Press indifferently ESC or OK to return to the main menu.

On the PC screen, that information is shown under the STATUS window.

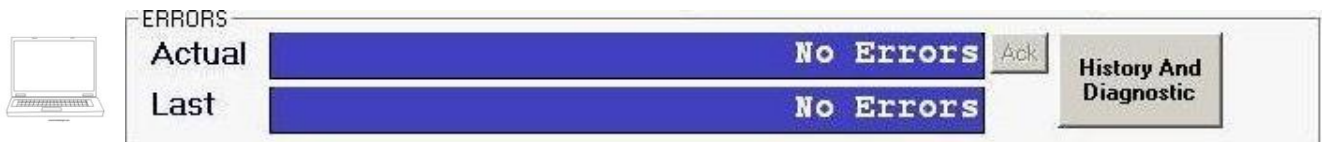

3.1.2 USER ACCESS PAGE

It's necessary to type the user password in order to enter into the system from the local panel.

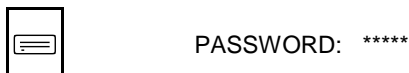

The device is supplied by the manufacturer with the default password: [OK ↑ ↓ ↑ ↓].

At the end of the login phase, the main menu will appear on the screen:

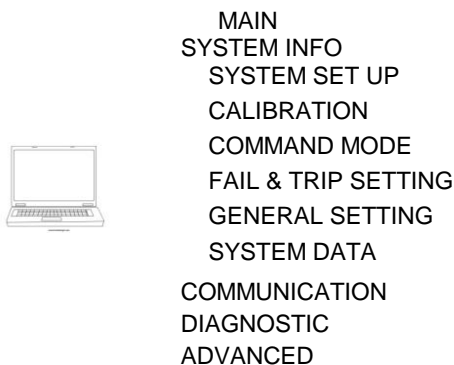

On the PC, a sequence of alfa-numerical digits is required (default is 12345) to access the system in remote mode.

To access to the password request there are to options:



INSTRUCTION MANUAL DPS (DIGITAL POSITION SYSTEM) QT series (Software)

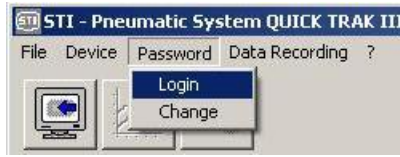

OR





INSTRUCTION MANUAL DPS (DIGITAL POSITION SYSTEM) QT series (Software)



3.2 SYSTEM INFO

↓			MAIN
OK			SYSTEM INFO
	OK		To return to main menu
	ESC		To return to main menu

In this page the system part number and the software revisions are displayed.



```

PART NUMBER .....
HC12 SW VERS. ....
DSP SW VERS. ....
PLD VERS. ....
HART REVISION 6.0
DEV. REVISION .....

```

The **part number** is the instrument serial number and it corresponds in the HART Protocol to the Device ID.
The **HC12 μ processor SW version** is the number corresponding to the SW release currently loaded on the QuickTrak controller.
The **DSP μ processor SW version** is the number corresponding to the SW release currently loaded on the QuickTrak controller.
The **PLD SW version** is the number corresponding to the SW release currently loaded on the QuickTrak controller.
The **HART Universal Revision Number** is a whole number indicating the HART major revision level supported by the field device.
The **Device Revision Number** defines the revision level of the command set supported by the field Device, including the device-specific commands.



INSTRUCTION MANUAL DPS (DIGITAL POSITION SYSTEM) QT series (Software)



3.3 SYSTEM SET UP

↓		MAIN
↓		SYSTEM INFO
OK		SYSTEM SET UP
	ESC	To return to main menu

By a sub-menu contained in this menu level, it's possible to adjust the main positioner functions.



ATTENTION: The system must be put into “out of service” in order to perform the “set up”. Please refer to chapter [COMMAND MODE](#).



CAUTION: When the system is “out of service” any parameters’ modifications can cause a movement of the actuator. Before making any changes, make sure that the plant and personnel are in a safe state to allow these movements.

On the LCD monitor, the following menu is displayed:



TRAVEL CONTROL
TUNING
INPUT CHAR.
INPUTS
OUTPUTS
RESET COMMAND

On the PC screen, that information is shown under the SYSTEM SETUP window.





INSTRUCTION MANUAL DPS (DIGITAL POSITION SYSTEM) QT series (Software)



3.3.1 TRAVEL CONTROL

↓			MAIN
↓			SYSTEM INFO
OK			SYSTEM SET UP
	OK		TRAVEL CONTROL
		ESC	To return to menu

With this set of commands, it is possible to configure the action of the actuator and special travel functions as limits or cut off functions.

On the LCD monitor, the following menu is displayed:



```

0 CTRL SIGNAL STEM ↑ / ↓
0 POSITION STEM ↑ / ↓
LTRAVEL POS.
LTRAVEL MODE OFF
HTRAVEL POS.
HTRAVEL MODE OFF
  
```

With the keys ↑ / ↓, it is possible to shift on the demanded line, and pushing the OK button, it is possible to change the function. The active selection will come out in reverse. The possible options for the low and high travel control mode are: OFF, LIMIT, CUT OFF.

3.3.1.1 0 CTRL SIGNAL

With this command, it is possible to select the position of the actuator stem corresponding to the 0 signal (4 mA).

KEY ↑ ("Stem in", in the PC software) → Actuator stem retracted at 4 mA
 KEY ↓ ("Stem out", in the PC software) → Actuator stem extended at 4 mA

With keys ↑ / ↓, it is possible to shift on the demanded line and pushing the OK button it is possible to change the function. The active selection will come out in reverse.



CAUTION: Modifying this parameter, the actuator can move. Before changing, make sure that the plant and personnel are in a safe state to allow these movements.

3.3.1.2 0 POSITION

With this command, it is possible to select the position of the actuator stem corresponding to the 0 output signal (0%).

KEY ↑ ("Stem in", in the PC software) → Actuator stem retracted at 0%
 KEY ↓ ("Stem out", in the PC software) → Actuator stem extended at 0%

With keys ↑ / ↓, it is possible to shift on the demanded line and pushing the OK button it is possible to change the function. The active selection will come out in reverse.

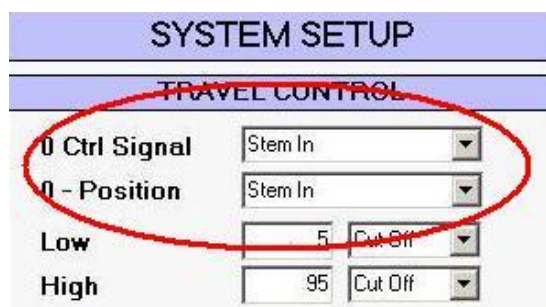



INSTRUCTION MANUAL DPS (DIGITAL POSITION SYSTEM) QT series (Software)



3.3.1.3 LOW TRAVEL POSITION

With this command, it is possible to define the low travel position for the actuator. The following information is displayed:



```
LTRAVEL POS.
5.0 %
PRESS OK TO CONFIRM
```

The second line value can be changed by pressing the key ↑ / ↓ and subsequently confirmed with OK. Press ESC to return to the previous menu.



CAUTION: Modifying this parameter, the actuator can move. Before changing, make sure that the plant and personnel are in a safe state to allow these movements.

On the PC, this function can be activated with the introduction of the value in the cell corresponding to the “low limit”.



SYSTEM SETUP	
TRAVEL CONTROL	
0 Ctrl Signal	Stem In
0 - Position	Stem In
Low	5 Cut Off
High	95 Cut Off

3.3.1.4 LOW TRAVEL MODE

With this command, it is possible to select the low travel control mode (OFF, LIMIT, CUT OFF). With the keys ↑ / ↓, it is possible to shift on the demanded line and pushing the OK button it is possible to change the function. The active selection will come out in reverse.



Select OFF to disable the travel control function.
 Select LIMIT to impose a software travel limit to the lower side of the actuator stroke.
 Select CUT OFF to impose a software cut off limit to the lower side of the actuator stroke.
 With CUT OFF function the actuator provides full thrust, that is one of the actuator’s chamber is pressurized with max pressure value (air supply pressure) and the other is vented to the atmosphere.



CAUTION: Modifying this parameter, the actuator can move. Before changing, make sure that the plant and personnel are in a safe state to allow these movements.

On the PC, this function can be activated with the selection of the option corresponding to the low travel control mode.



INSTRUCTION MANUAL DPS (DIGITAL POSITION SYSTEM) QT series (Software)



TRAVEL CONTROL	
0 Ctrl Signal	Stem In
0 - Position	Stem In
Low	5 Cut Off
High	95 Off Limit

3.3.1.5 HIGH TRAVEL POSITION

With this command, it is possible to define the high travel position for the actuator. The following information is displayed:



```
HTRAVEL POS.
95.0 %
PRESS OK TO CONFIRM
```

The second line value can be changed by pressing the key \uparrow / \downarrow and subsequently confirmed with OK. Press ESC to return to the previous menu.



CAUTION: Modifying this parameter, the actuator can move. Before changing, make sure that the plant and personnel are in a safe state to allow these movements.

On the PC this function can be activated with the introduction of the value in the cell corresponding to the "high limit".



SYSTEM SETUP	
TRAVEL CONTROL	
0 Ctrl Signal	Stem In
0 - Position	Stem In
Low	5 Cut Off
High	95 Cut Off

3.3.1.6 HIGH TRAVEL MODE

With this command, it is possible to select the high travel control mode (OFF, LIMIT, CUT OFF). With the keys \uparrow / \downarrow , it is possible to shift on the demanded line and pushing the OK button it is possible to change the function. The active selection will come out in reverse.



- Select OFF to disable the travel control function.
- Select LIMIT to impose a software travel limit to the higher side of the actuator stroke.
- Select CUT OFF to impose a software cut off limit to the higher side of the actuator stroke.
- With CUT OFF function the actuator provides full thrust, that is one of the actuator's chamber is pressurized with max pressure value (air supply pressure) and the other is vented to the atmosphere.



INSTRUCTION MANUAL DPS (DIGITAL POSITION SYSTEM) QT series (Software)



CAUTION: Modifying this parameter, the actuator can move. Before changing, make sure that the plant and personnel are in a safe state to allow these movements.

On the PC, this function can be activated with the selection of the option corresponding to the high travel control mode.

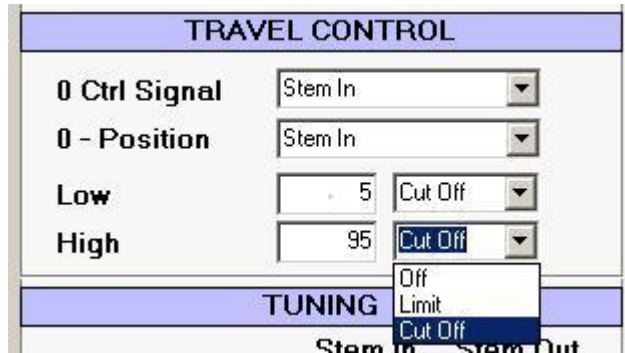

3.3.2 TUNING

↓			MAIN
↓			SYSTEM INFO
OK			SYSTEM SET UP
	↓		TRAVEL CONTROL
	OK		TUNING
		ESC	To return to menu

With this set of commands, it's possible to configure the positioner response parameters such as gain, integral function and dead band.

Selecting this function, the following menu is displayed:



PROPORTIONAL GAIN
SPEED CONTROL
DEAD BAND



CAUTION: Modifying this parameter, the actuator can move. Before changing, make sure that the plant and personnel are in a safe state to allow these movements.

3.3.2.1 PROPORTIONAL GAIN

With this command, it is possible to enter into a sub-menu:



PROP.GAIN STEM ↓ 3.5
PROP.GAIN STEM ↑ 3.5

Proportional gain is the multiplier of the error (difference between input signal and actuator actual position) and it is expressed in percent. It is active only for an error which is bigger than dead band value. A different gain for each stem direction can be imposed.

With the OK command selection, it is possible to enter into the parameter change page for the selected line (actuator stem direction) and modify the displayed value:



INSTRUCTION MANUAL DPS (DIGITAL POSITION SYSTEM) QT series (Software)



PROP.GAIN STEM ↓ (or STEM ↑)
3.5
PRESS OK TO CONFIRM

The second line value can be changed by pressing the key ↑ / ↓ and subsequently confirmed with OK. Press ESC to return to the previous menu.



WARNING: A wrong proportional gain value can generate actuator instability.

On the PC software, this parameter is called “Kp” and two cells are available (one for each direction) in “double” gain mode.



To set the value, double click on the selected cell and, the following window will appear:

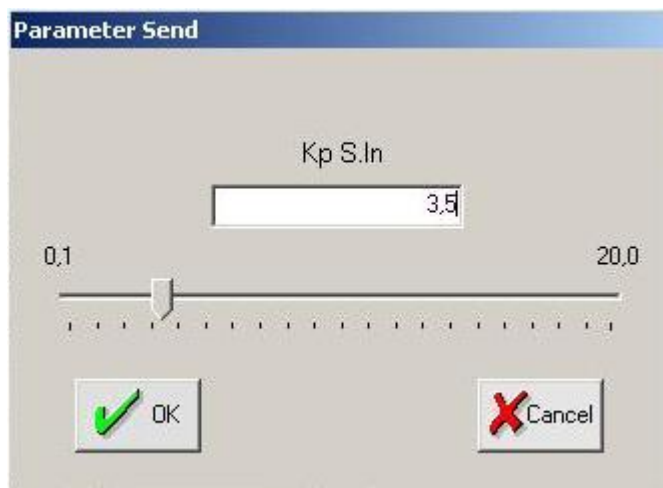

Insert the value and press “SEND” to confirm it or “Cancel” to exit.



WARNING: A wrong proportional gain value can generate actuator instability.

3.3.2.2 SPEED CONTROL

With this command, it is possible to modify stroke speed parameters. Selecting this command the following sub-menu is shown:



STROKE TIME ↓ 0
STROKE TIME ↑ 0
APPROACH FACTOR ↓ 12
APPROACH FACTOR ↑ 12

STROKE TIME is the value expressed in seconds of the stroking time for each direction (from 0% to 100%).



INSTRUCTION MANUAL DPS (DIGITAL POSITION SYSTEM) QT series (Software)



APPROACH FACTOR is a “damping” coefficient to be increased in order to avoid any overshooting when the actuator approaches the target position.

It can be set in a range between 0÷100 (0 = no control, 100 = maximum control). With the OK command selection, it is possible to enter the parameter change page for the selected line (actuator stem direction) and modify the displayed value:



```
STROKE TIME ↓ ( or ↑) APPROACH FACTOR ↓ ( or ↑)
0
APPROACH FACTOR ↓ ( or ↑)
12
PRESS OK TO CONFIRM
```

The second line value can be changed by pressing the key ↑ / ↓ and subsequently confirmed with OK. Press ESC to return to the previous menu.

On the PC software, those values are in the TUNING window.



TUNING		
	Stem In	Stem Out
Kp	3,5	3,5
Stroke Time (sec)	0,0	0,0
Approach Factor	12	12
Dead Band (%)	0,50	

To set the value, double click on the selected cell and the following window will appear:



Parameter Send

Stroke Time In (sec)

0,0
3000,0

✓ OK

✗ Cancel

Insert the value and press “SEND” to confirm or “Cancel” to exit.



CAUTION: Modifying this parameter, the actuator can move. Before changing, make sure that the plant and personnel are in a safe state to allow these movements.

3.3.2.3 DEAD BAND

With this command, it is possible to modify the dead band value. Dead band prevents (at expense of the accuracy) that the valve, in the controlled condition, keeps continuously hunting for the target position.



DEAD BAND
0.50
PRESS OK TO CONFIRM

It is expressed in terms of a total stroke percentage in a range of 0.05%÷20%.

	WARNING: A wrong dead band value can generate actuator instability.
---	--

	CAUTION: Modifying this parameter, the actuator can move. Before changing, make sure that the plant and personnel are in a safe state to allow these movements.
---	--

On the PC software, a single cell is available to modify the dead band value.



TUNING		
	Stem In	Stem Out
Kp	3,5	3,5
Stroke Time (sec)	0,0	0,0
Approach Factor	12	12
Dead Band (%)	0,50	

To set the value, double click on the cell, the following window will appear:





Parameter Send

Dead Band

0,05 20,00

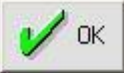





Insert the value and press “SEND” to confirm or “Cancel” to exit.

3.3.3 INPUT CHARACTERISTIC

↓			MAIN
↓			SYSTEM INFO
OK			SYSTEM SET UP
	↓		TRAVEL CONTROL
	↓		TUNING
	OK		INPUT CHAR.
		ESC	To return to menu

With those commands, it is possible to configure the relationship between the input signal and valve position set.

Selecting this function on the display, the following menu appears:



POSITION MODE **LINEAR** (or CUSTOMER)
CUSTOMER TABLE

In the first line, it's possible to move from linear to customer options (and vice versa) with the OK command. On the second line, with OK selection, it's possible to enter the changing point values page of the customer curve.



	TABLE	01/03
	SET POINT	TRAV.TARGET
	0.0	0.0
	10.0	10.0
	20.0	20.0
	30.0	30.0

In the first line, the current page is indicated, in the second line there are the column titles. In the following lines, there are: the position and the corresponding parameter values. The active field will come out in reverse. With the OK selection, it's possible to change the active data field. With the ↑ / ↓ commands, it's possible to modify all the available parameters. Changing the page number, it's possible to scroll the customer table.



	TABLE	02/03
	SET POINT	TRAV.TARGET
	40.0	40.0
	50.0	50.0
	60.0	60.0
	70.0	70.0



	TABLE	03/03
	SET POINT	TRAV.TARGET
	80.0	80.0
	90.0	90.0
	100.0	100.0



CAUTION: Modifying this parameter, the actuator can move. Before changing, make sure that the plant and personnel are in a safe state to allow these movements.



INSTRUCTION MANUAL DPS (DIGITAL POSITION SYSTEM) QT series (Software)



On the PC software is possible to select the curve type form the “INPUT CHAR” window that is located in “CFG” label:

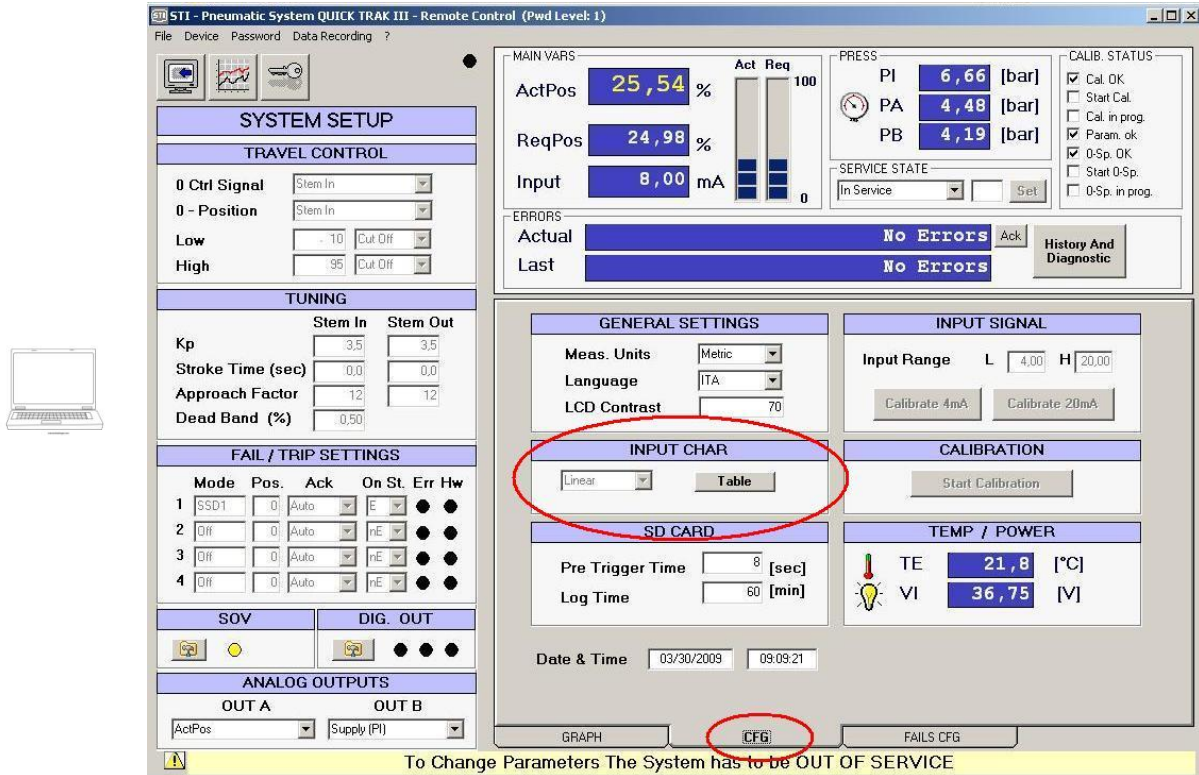

In case of “Customer Curve” selection, pushing the “Table” button, it’s possible to display the entire curve. From this page, it’s possible to modify the point values inserting the value into the cell or trailing the point position on the graph with the mouse.



INSTRUCTION MANUAL DPS (DIGITAL POSITION SYSTEM) QT series (Software)

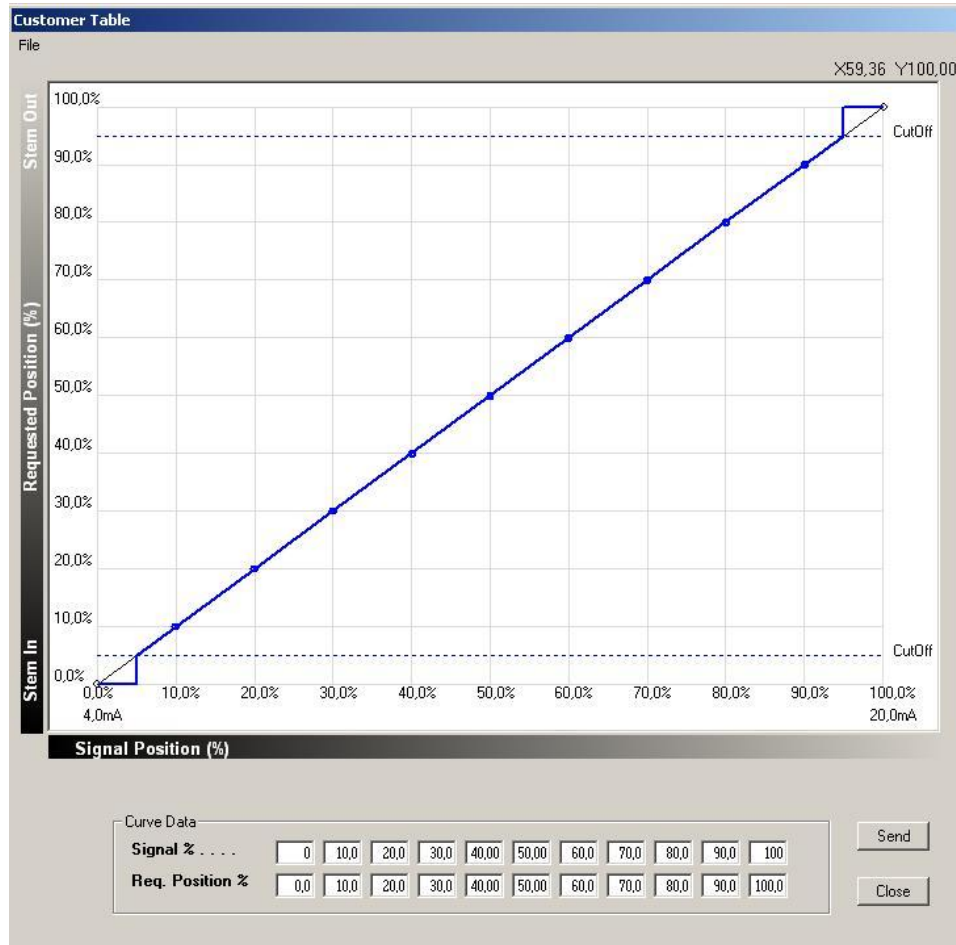

Press "SEND" to confirm the values or "CLOSE" to exit from this window. In order to use the transfer curve modified remember to select "Customer" instead "Linear" in INPUT CHAR window.



3.3.4 INPUTS

↓		MAIN
↓		SYSTEM INFO
OK		SYSTEM SET UP
	↓	TRAVEL CONTROL
	↓	TUNING
	↓	INPUT CHAR.
	OK	INPUTS
	ESC	To return to menu

With this set of commands, it's possible to configure the zero inlet signal and span.

Selecting this function, the following menu appears on the display:



INSTRUCTION MANUAL DPS (DIGITAL POSITION SYSTEM) QT series (Software)



```
INPUT RANGE L  XX.XmA  
INPUT RANGE H  XX.XmA  
CALIBRATE 4.0mA  
CALIBRATE 20.0mA
```

3.3.4.1 INPUT RANGE LOW

With this command, it's possible to set the lower range limit for the input signal.



```
INPUT RANGE LOW  
4.0 mA  
PRESS OK TO CONFIRM
```

The second line value can be changed by pressing the key \uparrow / \downarrow in a range between 0.0÷10.0 mA and subsequently confirmed with OK. Press ESC to return to the previous menu.

On the PC software, it's possible to insert the required value into the "Input Range L" cell in the INPUTS window.

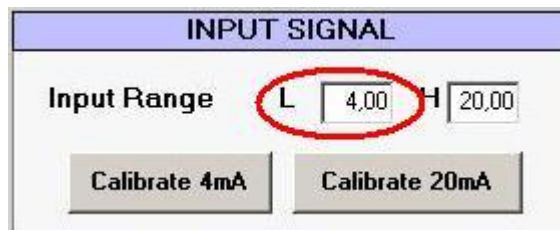

To set the value, double click on the selected cell and press "SEND" to confirm or "ABORT" to exit from this window.



CAUTION: Modifying this parameter, the actuator can move. Before changing, make sure that the plant and personnel are in a safe state to allow these movements.

3.3.4.2 INPUT RANGE HIGH

With this command, it's possible to set the upper range limit for the input signal.



```
INPUT RANGE HIGH  
20.0 mA  
PRESS OK TO CONFIRM
```

The second line value can be changed by pressing the key \uparrow / \downarrow in a range of between 10.0÷30.0 mA and subsequently confirmed with OK. Press ESC to return to the previous menu.

On the PC software, it is possible to insert the required value into the “Input Range H” cell in the INPUTS window.



INPUT SIGNAL		
Input Range	L	4,00
	H	20,00
<input type="button" value="Calibrate 4mA"/>		<input type="button" value="Calibrate 20mA"/>

To set the value, double click on the selected cell and press “SEND” to confirm or “ABORT” to exit from this window.

	CAUTION: Modifying this parameter, the actuator can move. Before changing, make sure that the plant and personnel are in a safe state to allow these movements.
---	--

3.3.4.3 CALIBRATE 4 mA or 20 mA

With this command, it's possible to calibrate the 4mA (or 20 mA) in order to set the input signal. A confirmation is required in order to start the 4mA/20mA calibration routine:



CALIBRATE 4.0mA ? or CALIBRATE 20.0mA ?

PRESS OK TO CONFIRM

On the PC software, is possible calibrate the two points by pushing the “Calibrate 4mA” and “Calibrate 20mA” buttons.



INPUT SIGNAL		
Input Range	L	4,00
	H	20,00
<input type="button" value="Calibrate 4mA"/>		<input type="button" value="Calibrate 20mA"/>

	CAUTION: Modifying this parameter, the actuator can move. Before changing, make sure that the plant and personnel are in a safe state to allow these movements.
---	--

A confirmation is required in order to start the 4mA/20mA calibration routine:



Alert
 Are you sure you want to perform a calibration 4mA?
<input type="button" value="Start Calibration 4mA"/> <input type="button" value="Cancel"/>

3.3.5 OUTPUTS

↓			MAIN
↓			SYSTEM INFO
OK			SYSTEM SET UP
	↓		TRAVEL CONTROL
	↓		TUNING
	↓		INPUT CHAR.
	↓		INPUTS
OK			OUTPUTS
		ESC	To return to menu

With this set of commands, it's possible to configure the available output channels.

Selecting this function on the display, the following menu appears:



ANALOG OUTPUT A
ANALOG OUTPUT B
DIGITAL OUTPUT1
DIGITAL OUTPUT2
DIGITAL OUTPUT3

3.3.5.1 ANALOG OUTPUT

When ANALOG OUTPUTs (A or B) are selected with the OK key, it's possible to enter the available analog output parameters page:



REQPOS	OFF/ON (required position, between 4÷20 mA)
ACTPOS	OFF/ON (actuator position, between 4÷20 mA)
INPUT	OFF/ON (input signal, between 4÷20 mA)
OUT1	OFF/ON (chamber 1 pressure, between 0÷10 bar)
OUT2	OFF/ON (chamber 2 pressure, between 0÷10 bar)
PRESSURE DELTA	OFF/ON (pressure difference, between -5÷5 bar)
TE	OFF/ON (temperature, between 0÷100°C)
SUPPLY	OFF/ON (supply pressure, between 0÷10 bar)
VI	OFF/ON (inside control panel voltage, 0÷100 Vdc)

It's possible to choose the required parameter, in order to associate it to the selected output channel for the reproduction of the indicated signal in a range from 4mA to 20mA. Pressing OK to confirm the choice, the ON indication will be pointed out on the selected channel. Press ESC to return to the previous menu.

On the PC software, it's possible to impose the output parameter by its selection in correspondence of OUT A or OUT B.

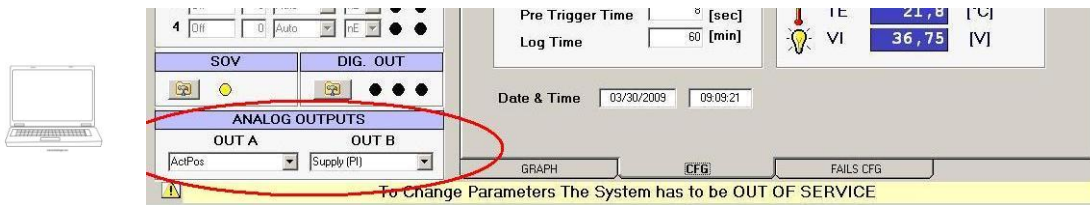

NEW FUNCTION

Starting from Release 4.01 ONLY from PC software it is possible to select "User ActPos" that allow the user to have a special position feedback. The User ActPos offsets and gain are configurable in **STI expert menu** in probe label.

3.3.5.2 DIGITAL OUTPUT

When DIGITAL OUTPUTs (1,2 or 3) are selected with the OK key, it's possible to enter into the available digital output parameters page:



INSTRUCTION MANUAL DPS (DIGITAL POSITION SYSTEM) QT series (Software)



WAITING ACK	OFF/ON
OUT SVC	OFF/ON
TRIP 1	OFF/ON
TRIP 2	OFF/ON
TRIP 3	OFF/ON
TRIP 4	OFF/ON
PRESSURE FAIL LOW	OFF/ON
SIGN.FAIL	OFF/ON
HIGH SIGN.FAIL	OFF/ON
POS.EXC. ERROR	OFF/ON
POS.EXC. WARN.	OFF/ON
PROBE ERROR	OFF/ON
POWER FAIL	OFF/ON
HARDWARE ERROR	OFF/ON
ENCODER ERROR	OFF/ON
EXC.FRICT.ERR.	OFF/ON
ENC. INDEX ERR.	OFF/ON

It's possible to choose the required fail, warning or error activation, in order to associate it to the selected digital output channel. Pressing OK to confirm the choice, the ON indication will be pointed out on the selected channel. Press ESC to return to the previous menu.

On the PC software, pushing the Dig. Out Config. button located in the DIG. OUT window, it's possible to impose the output parameter by its selection in correspondence of OUT 1, OUT 2 or OUT 3.

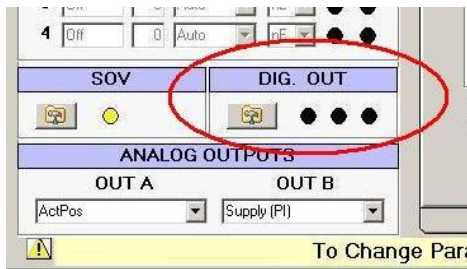



INSTRUCTION MANUAL DPS (DIGITAL POSITION SYSTEM) QT series (Software)



Digital Output Configuration

	OUT 1	OUT 2	OUT 3
Waiting Ack	<input type="checkbox"/>	<input type="checkbox"/>	<input type="checkbox"/>
Out Of Service	<input type="checkbox"/>	<input type="checkbox"/>	<input type="checkbox"/>
Trip 1	<input type="checkbox"/>	<input type="checkbox"/>	<input type="checkbox"/>
Trip 2	<input type="checkbox"/>	<input type="checkbox"/>	<input type="checkbox"/>
Trip 3	<input type="checkbox"/>	<input type="checkbox"/>	<input type="checkbox"/>
Trip 4	<input type="checkbox"/>	<input type="checkbox"/>	<input type="checkbox"/>
Pressure Fail	<input type="checkbox"/>	<input type="checkbox"/>	<input type="checkbox"/>
Signal Fail (<min)	<input type="checkbox"/>	<input type="checkbox"/>	<input type="checkbox"/>
Signal Fail (>max)	<input type="checkbox"/>	<input type="checkbox"/>	<input type="checkbox"/>
Position Excess Error	<input type="checkbox"/>	<input type="checkbox"/>	<input type="checkbox"/>
Position Excess Warning	<input type="checkbox"/>	<input type="checkbox"/>	<input type="checkbox"/>
Probe Error	<input type="checkbox"/>	<input type="checkbox"/>	<input type="checkbox"/>
Power Fail	<input type="checkbox"/>	<input type="checkbox"/>	<input type="checkbox"/>
Hardware Error	<input type="checkbox"/>	<input type="checkbox"/>	<input type="checkbox"/>
Encoder Error	<input type="checkbox"/>	<input type="checkbox"/>	<input type="checkbox"/>
Excess Friction Error	<input type="checkbox"/>	<input type="checkbox"/>	<input type="checkbox"/>
Encoder Index Error	<input type="checkbox"/>	<input type="checkbox"/>	<input type="checkbox"/>

Abort Send

The status of OUT 1, OUT 2 and OUT 3 is shown in DIG OUT window. When a function is selected, the related output is deactivated when the event is true.



INSTRUCTION MANUAL DPS (DIGITAL POSITION SYSTEM) QT series (Software)



For example: Dig OUT1 is set on "Out of service" . When the service state is "In Service" the digital output 1 is activated, when the service state pass in "Out of service" the digital output 1 is turned off.



Digital Output Configuration window showing settings for OUT 1, OUT 2, and OUT 3. The "Out Of Service" checkbox for OUT 1 is highlighted with a red circle.

	OUT 1	OUT 2	OUT 3
Waiting Ack	<input type="checkbox"/>	<input type="checkbox"/>	<input type="checkbox"/>
Out Of Service	<input checked="" type="checkbox"/>	<input type="checkbox"/>	<input type="checkbox"/>
Trip 1	<input type="checkbox"/>	<input checked="" type="checkbox"/>	<input type="checkbox"/>
Trip 2	<input type="checkbox"/>	<input type="checkbox"/>	<input checked="" type="checkbox"/>
Trip 3	<input type="checkbox"/>	<input type="checkbox"/>	<input type="checkbox"/>
Trip 4	<input type="checkbox"/>	<input type="checkbox"/>	<input type="checkbox"/>
Pressure Fail	<input type="checkbox"/>	<input type="checkbox"/>	<input type="checkbox"/>
Signal Fail (<min)	<input type="checkbox"/>	<input type="checkbox"/>	<input type="checkbox"/>
Signal Fail (>max)	<input type="checkbox"/>	<input type="checkbox"/>	<input type="checkbox"/>
Position Excess Error	<input type="checkbox"/>	<input type="checkbox"/>	<input type="checkbox"/>
Position Excess Warning	<input type="checkbox"/>	<input type="checkbox"/>	<input type="checkbox"/>
Probe Error	<input type="checkbox"/>	<input type="checkbox"/>	<input type="checkbox"/>
Power Fail	<input type="checkbox"/>	<input type="checkbox"/>	<input type="checkbox"/>
Hardware Error	<input type="checkbox"/>	<input type="checkbox"/>	<input type="checkbox"/>
Encoder Error	<input type="checkbox"/>	<input type="checkbox"/>	<input type="checkbox"/>
Excess Friction Error	<input type="checkbox"/>	<input type="checkbox"/>	<input type="checkbox"/>
Encoder Index Error	<input type="checkbox"/>	<input type="checkbox"/>	<input type="checkbox"/>

Buttons: Abort, Send



STI Pneumatic System QUICK TRAK III - Remote Control (PwL Level: 2) window. The SERVICE STATE dropdown menu is highlighted with a red circle. A red arrow points from the SERVICE STATE dropdown to the DIG. OUT section in the FAIL / TRIP SETTINGS area.

MAIN VARS: ActPos 0,01 %, ReqPos 0,00 %, Input 4,00 mA

PRESS: PI 6,68 [bar], PA 6,67 [bar], PB 0,00 [bar]

SERVICE STATE: In Service

ERRORS: Actual No Errors, Last No Errors

GENERAL SETTINGS: Meas. Units Metric, Language ITA, LCD Contrast 70

INPUT SIGNAL: Input Range L 4,00 H 20,00

INPUT CHAR: Customer, Table

SD CARD: Pre Trigger Time 8 [sec], Log Time 60 [min]

TEMP / POWER: TE 24,9 [°C], VI 36,75 [V]

FAIL / TRIP SETTINGS: DIG. OUT section highlighted with a red circle.

ANALOG OUTPUTS: OUT A, OUT B

Date & Time: 03/30/2009 13:32:47

To Change Parameters The System has to be OUT OF SERVICE



INSTRUCTION MANUAL DPS (DIGITAL POSITION SYSTEM) QT series (Software)



STI - Pneumatic System QUICK TRAK III - Remote Control (Pwd Level: 2)

File Device Password Data Recording ?

STI

SYSTEM SETUP

TRAVEL CONTROL

0 Ctrl Signal Stem In
0 - Position Stem In
Low 5 Cut Off
High 95 Cut Off

TUNING

	Stem In	Stem Out
Kp	3.5	3.5
Stroke Time (sec)	0.0	0.0
Approach Factor	12	12
Dead Band (%)	0.50	

FAIL / TRIP SETTINGS

Mode	Pos.	Ack	On St.	Err	Hw
1 SSDI	0	Auto	E		
2 Off	0	Auto	nE		
3 Off	0	Auto	nE		
4 Off	0	Auto	nE		

SOV

SOV indicator light: ●

DIG. OUT

DIG. OUT indicator lights: ● ● ●

ANALOG OUTPUTS

OUT A	OUT B
ActPos	Supply (PI)

MAIN VARS

ActPos 0,00 %
ReqPos 0,00 %
Input 4,00 mA

PRESS

PI 6,68 [bar]
PA 6,67 [bar]
PB 0,00 [bar]

SERVICE STATE

Out Of Service

ERRORS

Actual No Errors
Last No Errors

GENERAL SETTINGS

Meas. Units Metric
Language ITA
LCD Contrast 70

INPUT SIGNAL

Input Range L 4,00 H 20,00
Calibrate 4mA Calibrate 20mA

INPUT CHAR

Customer Table

SD CARD

Pre Trigger Time 8 [sec]
Log Time 60 [min]

CALIBRATION

Start Calibration

TEMP / POWER

TE 24,9 [°C]
VI 36,67 [V]

Date & Time 03/30/2009 13:33:41

GRAPH CFG FAILS CFG

Changing Parameters The System Can MOVE!





INSTRUCTION MANUAL DPS (DIGITAL POSITION SYSTEM) QT series (Software)



3.4 CALIBRATION

↓			MAIN
↓			SYSTEM INFO
↓			SYSTEM SET UP
OK			CALIBRATION
	ESC		To return to main menu

With this selection is possible to activate the instrument calibration routine.



Before to perform a calibration it's suggested to set to 1,0 the values of *Kp stem in* and *Kp stem out*.

If the customer tries to make a calibration when the system is "in service", the following message will be shown:



REFUSED REQUEST:
SVCSTATE MUST BE OUT!
PRESS ESC/OK TO EXIT

First step of the calibration is the setting (by means of ↑ / ↓ buttons) of the probe constant. This value is printed on the probe label.



PROBE CONSTANT
2800
PRESS OK TO CONFIRM



CAUTION: While the system is in calibration mode, the controller will move the cylinder (and process valve) automatically through various positions regardless of the state of the normal input command, including the fully open and fully close position. Before calibrating the system, make sure that the plant and personnel are in a safe state to allow these automatic functions.

Second step is the calibration confirmation:



CALIBRATION ?
PRESS OK TO CONFIRM

Once the calibration operation is confirmed with OK, the following page will be displayed on video:



SYSTEM CALIBRATION.....
PLEASE WAIT

And it will remain active during the execution of calibration routine.
Once the operation is completed the following message is shown.



INSTRUCTION MANUAL DPS (DIGITAL POSITION SYSTEM) QT series (Software)



SYSTEM CALIBRATED
PRESS ESC TO MENU
PRESS OK TO GO IN SVC

Pressing OK, the system enters the in service state automatically.
Pressing ESC the main menu will be displayed.

On the PC software, it is possible to start calibration selecting the “start calibration” button located in CFG tag.

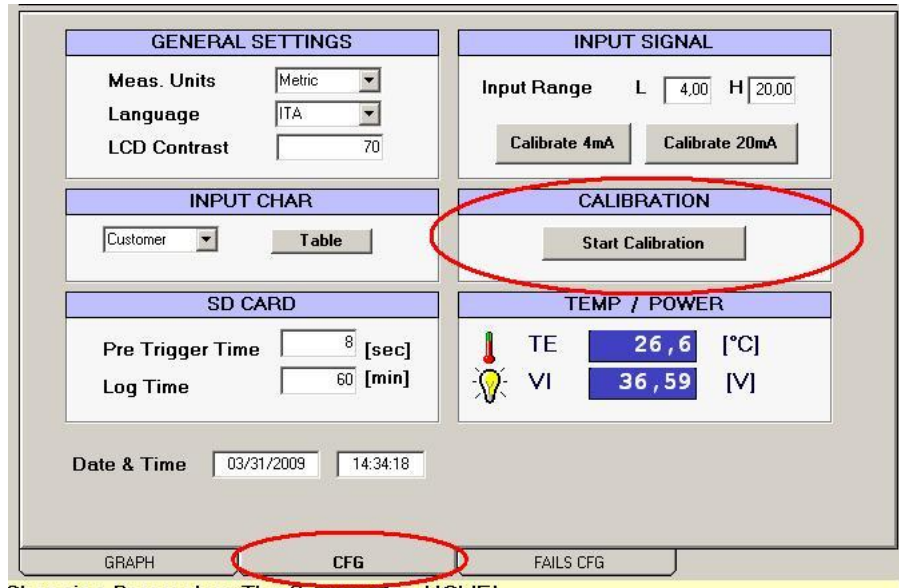

A confirmation is required in order to start the calibration routine:

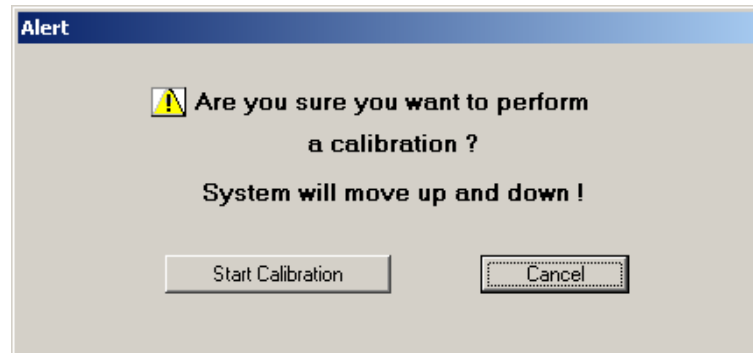

Calibration status is shown on the upper side on the right of the panel:

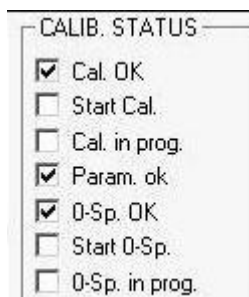



INSTRUCTION MANUAL DPS (DIGITAL POSITION SYSTEM) QT series (Software)



3.5 SD CARD

This NEW function is available only on PC software since the DSP release 4.01
Inserting a SD card into the slot on the display board an automatic process of data collection is activated.
Automatically will be created a folder for each month and year named DIAGyymm (yy: year mm: month). And will be stored 2 kind of files:

- **History file:** stores parameters periodically and the time between a file and the other is set in LOG TIME
- **Event file:** store parameters on event. The event that cause the storing of the file are:
 - Signal < min
 - Signal > max
 - Position error
 - Position warning
 - Probe error
 - Trips

The event file is a snapshot of 20 sec. (100 Hz sampling rate frequency) triggered on event with the pre-trigger time set by user.

It is possible to configure the storing parameters in SD CARD area in CFG tag.

NEW FUNCTION



SD CARD	
Pre Trigger Time	<input type="text" value="8"/> [sec]
Log Time	<input type="text" value="60"/> [min]

The SD Card has to be formatted in FAT 16 (up to 2GB capacity).



INSTRUCTION MANUAL DPS (DIGITAL POSITION SYSTEM) QT series (Software)



3.6 COMMAND MODE

↓			MAIN
↓			SYSTEM INFO
↓			SYSTEM SET UP
↓			CALIBRATION
OK			COMMAND MODE
	ESC		To return to main menu

With this selection, it is possible to change the system service status.

The local control panel displays:



SERVICE **OUT** / IN
MANUAL

In the first line the active option is displayed in reverse.

On the PC screen, that information is shown in the SERVICE STATE window:



3.6.1 SERVICE OUT / IN

↓			MAIN
↓			SYSTEM INFO
↓			SYSTEM SET UP
↓			CALIBRATION
OK			COMMAND MODE
	OK		SERVICE OUT/IN
		ESC	To return to menu

When a different option is selected, a confirmation is required in order to change the system service status.

If the system is out of service, the OUT option is displayed in reverse and the IN selection is made pressing OK.

The following message appears:



SERVICE STATE:
OUT SVC -> IN SVC
PRESS OK TO CONFIRM

The OK selection is required to confirm the option.

In order to go back to out of service state, the following confirmation message is displayed:



SERVICE STATE:
IN SVC -> OUT SVC
PRESS OK TO CONFIRM

In order to go in service state, the system must be calibrated, if this condition is not satisfied, the error message

is displayed:



REFUSED REQUEST:
INVALID SYSTEM STATE!
PRESS ESC/OK TO EXIT

On the PC, it is possible to choose the service state, selecting the service status on the pull-down menu in the command mode cell.



CAUTION The plant operator has the responsibility to make sure that automatic cycling of the process valve, will not cause any damage to property or personnel before issuing the “in service” command. This includes making sure that personnel and equipment are clear of moving parts of the cylinder and process valve and that the plant process has been made safe by bypassing the process valve.

3.6.2 MANUAL

↓			MAIN
↓			SYSTEM INFO
↓			SYSTEM SET UP
↓			CALIBRATION
OK			COMMAND MODE
	↓		SERVICE OUT/IN
	OK		MANUAL
		ESC	To return to menu

Selecting this option, the system changes from the automatic control mode to the manual mode (Direct Mode). To activate “Manual mode”, the system must be calibrated and “out of service”, in case of one or both conditions are not satisfied, the error message is displayed:



REFUSED REQUEST:
INVALID SYSTEM STATE!
PRESS ESC/OK TO EXIT

In manual mode, the required (variable value with ↑ / ↓ buttons) and current position are displayed.



```

OUT SVC    CAL OK
-----
REQPOS    XXX.X%
ACTPOS    XXX.X%

```

Operating with PC selecting the “Manual” option in the service pull-down menu, it’s possible to insert the required position cell and confirm it, pushing the “Set” button.



INSTRUCTION MANUAL DPS (DIGITAL POSITION SYSTEM) QT series (Software)





INSTRUCTION MANUAL DPS (DIGITAL POSITION SYSTEM) QT series (Software)



3.7 FAIL & TRIP SETTING

↓			MAIN
↓			SYSTEM INFO
↓			SYSTEM SET UP
↓			CALIBRATION
↓			COMMAND MODE
OK			FAIL & TRIP SETTING
	ESC		To return to main menu

With this selection, it's possible to define the system behaviour in case of pressure, power or signal failure and/or activation of a trip signal.

This command displays the following sub menu:



- SOV CONFIGURATION
- POS.EXCESS FAIL MODE
- POWER FAIL MODE
- SIGNAL FAIL MODE
- PRESSURE FAIL MODE
- MODE FOR TRIP1
- MODE FOR TRIP2
- MODE FOR TRIP3
- MODE FOR TRIP4

On the PC some of these options are displayed and can be customized in the main window, others are available in "FAILS CFG" tag.



	Mode	Pos.	Ack	On St.	Err	Hw
1	SSD1	0	Auto	E	●	●
2	Off	0	Auto	nE	●	●
3	Off	0	Auto	nE	●	●
4	Off	0	Auto	nE	●	●

SOV **DIG. OUT**

ANALOG OUTPUTS

OUT A **OUT B**

ActPos Supply (PI)

To Change Param



INSTRUCTION MANUAL DPS (DIGITAL POSITION SYSTEM) QT series (Software)

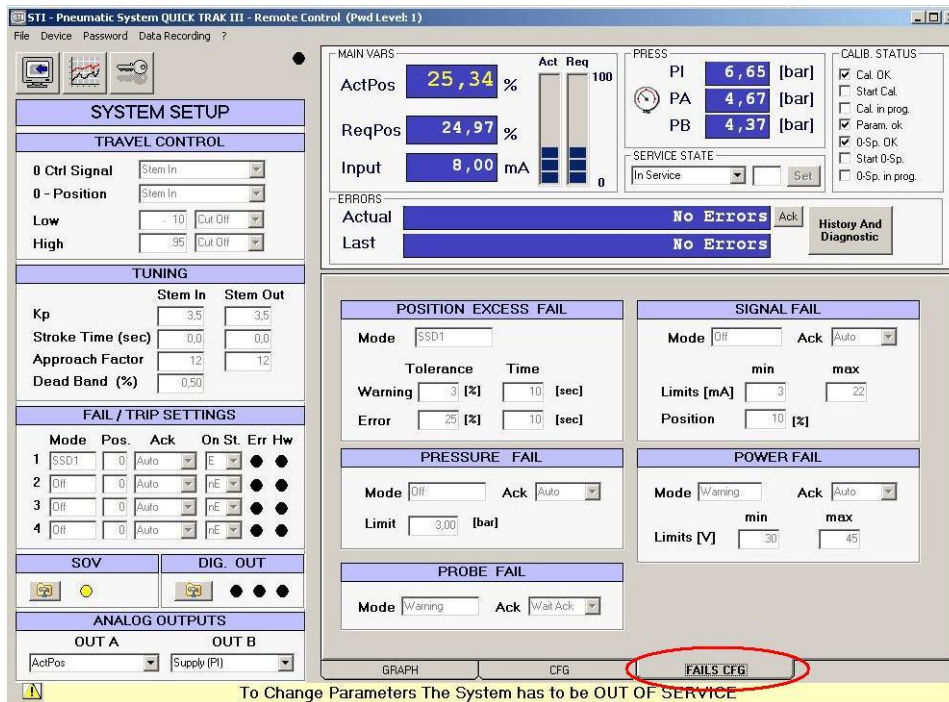

3.7.1 SOV CONFIGURATION

↓			MAIN
↓			SYSTEM INFO
↓			SYSTEM SET UP
↓			CALIBRATION
↓			COMMAND MODE
↓			FAIL & TRIP SETTING
OK			SOV CONFIGURATION
	OK		
		ESC	To return to menu

Selecting this option, it's possible to display and modify the system configuration provided for the solenoid valves (SOV).

The following page is displayed:



```

SOV N. 3 SOV1 SOV2 SOV3
RUNNING  ON OFF OFF
SAFETY SD1 OFF OFF OFF
SAFETY SD2 ON  OFF OFF
SAFETY SD3 OFF OFF OFF
    
```

In the first line, it's possible to configure the system SOV number (1, 2 or 3), in the second line the SOV configuration provided for running mode (normal operation mode); in next lines the SOV configuration provided for three specific cases: SAFETY SHUT DOWN 1, 2 and 3.

The active field will come out in reverse. With the OK selection, it's possible to change the active data field. With the ↑ / ↓ keys, it's possible to change the parameter option.



INSTRUCTION MANUAL DPS (DIGITAL POSITION SYSTEM) QT series (Software)



On the PC software, it's possible to display the SOV configuration, pressing the corresponding button in the "SOV Configuration" window.

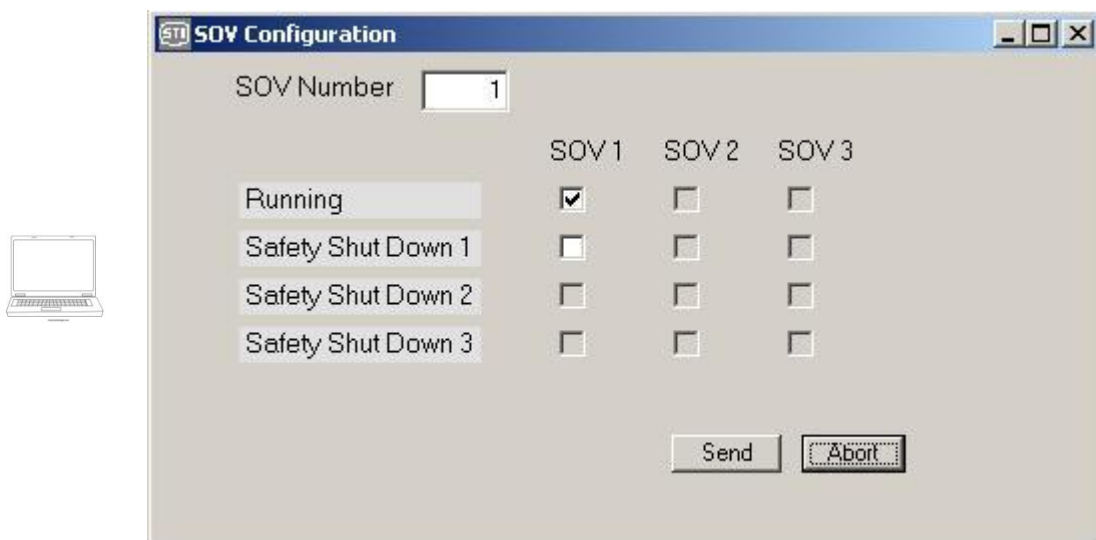
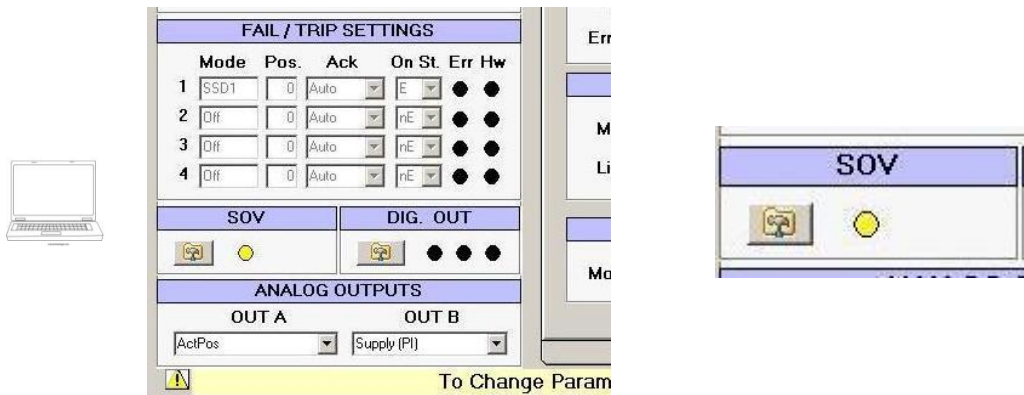

To set the SOV number, double click on the corresponding cell, and press "SEND" to confirm the value or "ABORT" to exit from this window.

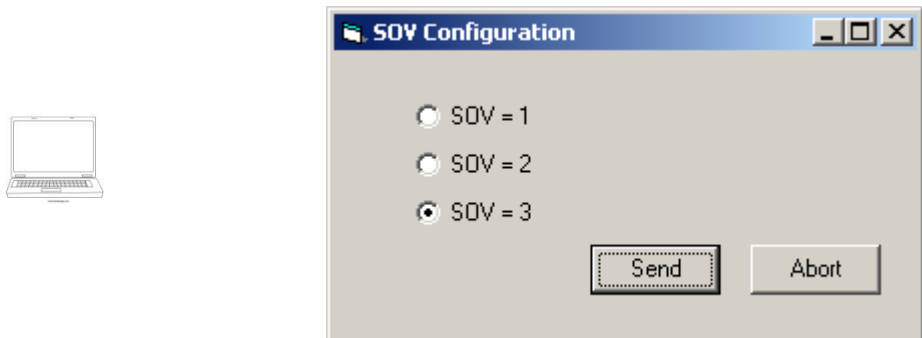

To set the SOV configuration in case of running, safety shut down 1, 2, 3 modes, check the selected options and press "SEND" to confirm the entire selection or "ABORT" to exit from this window.

A new function is included starting from 4.01 firmware version. Available ONLY in PC sw enabled only with password level 2 (expert mode).



INSTRUCTION MANUAL DPS (DIGITAL POSITION SYSTEM) QT series (Software)



NEW FUNCTION

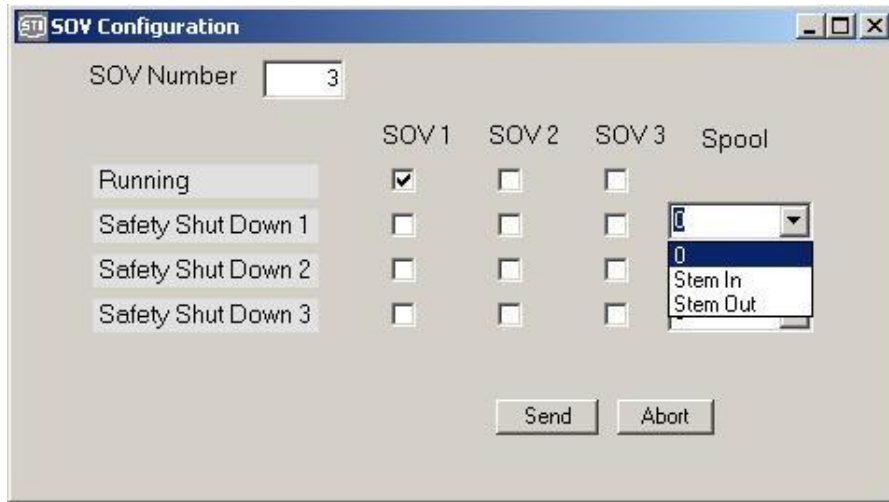

Now is possible to set the spool movement on safety shutdown (1,2 or 3) in order to improve the stroking time. This function is used only when the actuator is in a limit position (0% or 100%)



CAUTION: The function has to be configured **ONLY** by expert user. The spool has to move according to the pneumatic circuit.

3.7.2 POSITION EXCESS FAIL MODE

↓			MAIN
↓			SYSTEM INFO
↓			SYSTEM SET UP
↓			CALIBRATION
↓			COMMAND MODE
OK			FAIL & TRIP SETTING
	↓		SOV CONFIGURATION
	OK		POS.EXCESS FAIL MODE
		ESC	To return to menu

Selecting this command, it's possible to configure the max admissible position error and warning (difference between the required and the actual position) and the actions to be executed, if these limits are exceeded.

The following menu is displayed:



```

ERROR MODE      OFF
EXCESS ERROR    25.0%
ERROR SECONDS   10SEC
EXCESS WARN.    3.0%
WARN. SECONDS   8SEC
  
```

On the PC, it's possible to configure all the selections and values in the "Position excess fail" panel.



3.7.2.1 ERROR MODE

The first line allows to configure the action to be executed in case of excess position error; the selection can be made by selecting the line with the up / down buttons and scrolling the options by pushing the OK key. The available options are:



OPTION	APPLICABILITY	EXECUTED ACTION
OFF	All cases	Nothing
SAFETY SD1	At least one solenoid valve available	The actuator goes to the "SAFETY SD1" position corresponding to the "SAFETY SD1" SOV configuration.
SAFETY SD2	At least two solenoid valves available	The actuator goes to the "SAFETY SD2" position corresponding to the "SAFETY SD2" SOV configuration.
SAFETY SD3	Three solenoid valves available	The actuator goes to the "SAFETY SD3" position corresponding to the "SAFETY SD3" SOV configuration.

On the PC, it's possible to configure the position error mode.

To set the value, double click on the corresponding cell, click the option and press "Ok" to confirm it or "Cancel" to exit.



3.7.2.2 EXCESS ERROR

With this command, it's possible to set the max error position value (tolerance).



```
EXCESS ERROR
3.0 %
PRESS OK TO CONFIRM
```

The value can be changed by pressing the ↑ and ↓ keys in a range between 0÷100% and subsequently confirmed with OK. Press ESC to return to the previous menu.

On the PC, it's possible to configure the parameter in the "Position excess fail" panel.



INSTRUCTION MANUAL DPS (DIGITAL POSITION SYSTEM) QT series (Software)



POSITION EXCESS FAIL			
Mode	<input style="width: 95%;" type="text" value="SSD1"/>		
	Tolerance	Time	
Warning	<input style="width: 40%;" type="text" value="3"/> [%]	<input style="width: 40%;" type="text" value="10"/> [sec]	
Error	<input style="width: 40%;" type="text" value="25"/> [%]	<input style="width: 40%;" type="text" value="10"/> [sec]	

To set the value, double click on the corresponding cell, input the value and press “Ok” to confirm it or “Cancel” to exit.



Parameter Send

Error Position Tolerance

3.7.2.3 ERROR SECONDS

In case of error condition, this parameter defines the waiting time before the alarm is activated.



ERROR SECONDS
10 SEC
 PRESS OK TO CONFIRM

The value can be changed by pressing the ↑ and ↓ keys in a range between 0÷1000 seconds and subsequently confirmed with OK. Press ESC to return to the previous menu.

From the PC, it's possible to configure the parameter in the “Position excess fail” panel located in “FAILS CFG” tag.



POSITION EXCESS FAIL			
Mode	<input style="width: 95%;" type="text" value="SSD1"/>		
	Tolerance	Time	
Warning	<input style="width: 40%;" type="text" value="3"/> [%]	<input style="width: 40%;" type="text" value="10"/> [sec]	
Error	<input style="width: 40%;" type="text" value="25"/> [%]	<input style="width: 40%;" type="text" value="10"/> [sec]	

To set the value, double click on the corresponding cell, input the value and press “Ok” to confirm it or “Cancel” to exit.



INSTRUCTION MANUAL DPS (DIGITAL POSITION SYSTEM) QT series (Software)

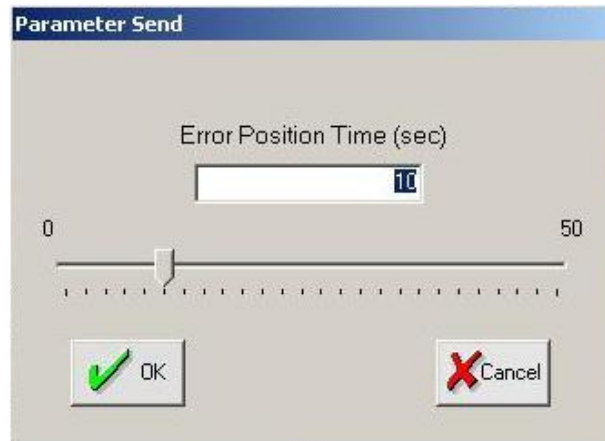

3.7.2.4 EXCESS WARNING

The selection allows to set the max warning position value (tolerance) in the 0÷100% range.



EXCESS WARN.
3.0 %
PRESS OK TO CONFIRM

The value can be changed by pressing the ↑ and ↓ keys and subsequently confirmed with OK. Press ESC to return to the previous menu.

On the PC, it's possible to configure the parameter in the "Position excess fail" panel.

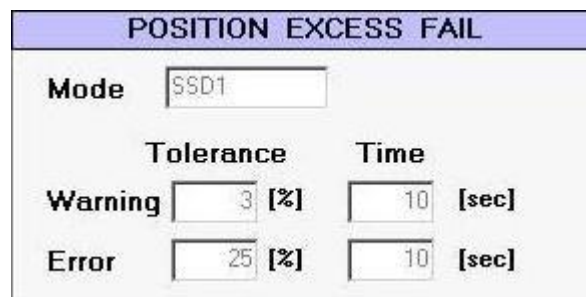

To set the value, double click on the corresponding cell, input the value and press "OK" to confirm it or "Cancel" to exit.

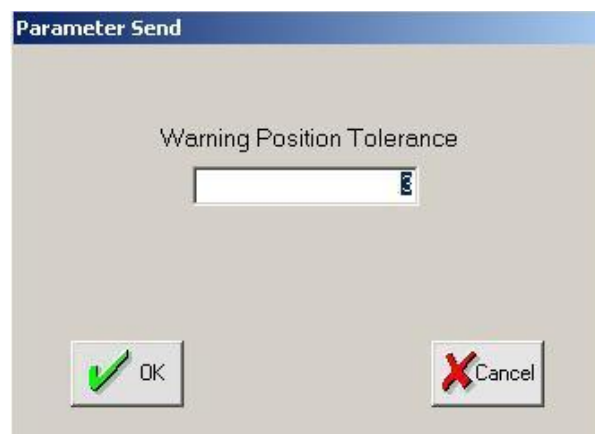

3.7.2.5 WARNING SECONDS

In case of warning condition this value is the waiting time before the alarm is activated. It's possible to insert a value in the range of 0÷1000 seconds.



WARN. SECONDS
10 SEC
PRESS OK TO CONFIRM

The value can be changed by pressing the ↑ and ↓ keys and confirmed with OK. Press ESC to return to the previous menu.

On the PC, it's possible to configure the parameter in the "Position excess fail" panel.



POSITION EXCESS FAIL			
Mode	<input type="text" value="SSD1"/>		
	Tolerance		Time
Warning	<input type="text" value="3"/> [%]	<input type="text" value="10"/> [sec]	
Error	<input type="text" value="25"/> [%]	<input type="text" value="10"/> [sec]	

To set the value, double click on the corresponding cell, input the value and press "OK" to confirm it or "Cancel" to exit.





Parameter Send

Warning Position Time (sec)

0 50



 OK

 Cancel

3.7.3 POWER FAIL MODE

↓			MAIN
↓			SYSTEM INFO
↓			SYSTEM SET UP
↓			CALIBRATION
↓			COMMAND MODE
OK			FAIL & TRIP SETTING
	↓		SOV CONFIGURATION
	↓		POS.EXCESS FAIL MODE
	OK		POWER FAIL MODE
		ESC	To return to menu

Selection of this command, allows to define the minimum and maximum admissible power to the main PCB,

and to configure the power fail condition.

The displayed menu is:



ERROR MODE OFF
END MODE AUTO
POWER LIMIT

On the PC, is possible to configure all the selections and values in the “Power fail” panel.



POWER FAIL

Mode Ack

min max

Limits [V]

3.7.3.1 ERROR MODE

The first line allows to configure the action to be executed in case of low voltage supply power. The selection can be made by selecting the line with the up / down buttons and scrolling the options by pushing the OK key. The available options are:



OPTION	APPLICABILITY	EXECUTED ACTION
OFF	All cases	Nothing
SAFETY SD1	At least one solenoid valve available	The actuator goes to the “SAFETY SD1” position corresponding to the “SAFETY SD1” SOV configuration.
SAFETY SD2	At least two solenoid valves available	The actuator goes to the “SAFETY SD2” position corresponding to the “SAFETY SD2” SOV configuration.
SAFETY SD3	Three solenoid valves available	The actuator goes to the “SAFETY SD3” position corresponding to the “SAFETY SD3” SOV configuration.
WARNING	All cases	On the positioner display will be shown a warning message

On the PC, it's possible to configure the power error mode.

To set the value, double click on the corresponding cell, click the option and press “SEND” to confirm it or “ABORT” to exit.



Error Mode

- Off
- Safety Shut Down 1
- Safety Shut Down 2
- Safety Shut Down 3
- Spool
- Freeze
- Ack
- External SOV
- Warning



INSTRUCTION MANUAL DPS (DIGITAL POSITION SYSTEM) QT series (Software)



3.7.3.2 END MODE

The end mode option allows to configure the action to be executed at the end of the error conditions, the selection can be made by selecting the line with the up / down buttons and scrolling the options by pushing the OK key. The available options are:



OPTION	EXECUTED ACTION
AUTO	Automatic return to normal working condition without waiting for confirmation.
WAIT ACK	A confirmation is required before returning to normal working condition.
WAIT NOERR	Automatic return to normal working condition only if all error conditions have been cleared.

On the PC, it is possible to choose the power fail end mode, selecting the option on the corresponding pull-down menu.

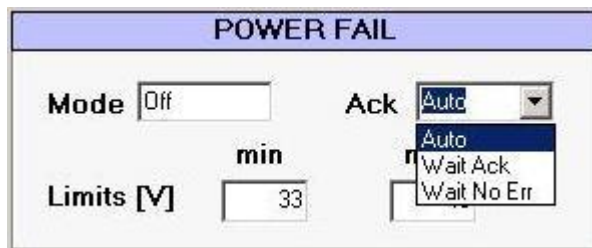

3.7.3.3 POWER LIMIT

A list with high and low power limit values is displayed:



```
POW.LIMIT LOW 33.0V
POW.LIMIT HIGH 45.0V
```

Selecting the first line, it is possible to modify the low voltage supply limit value.



```
POW. LIMIT LOW
33.0 V
PRESS OK TO CONFIRM
```

The admissible range is between 0 to 50 Vdc.

The value can be changed by pressing the ↑ and ↓ keys and subsequently confirmed with OK. Press ESC to return to the previous menu.

Selecting the second line, it is possible to modify the high voltage supply limit value.



```
POW. LIMIT HIGH
45.0 V
PRESS OK TO CONFIRM
```

The admissible range is between 30 to 100 Vdc.

The value can be changed by pressing the ↑ and ↓ keys and subsequently confirmed with OK. Press ESC to return to the previous menu.

On the PC, it is possible to modify the low and high power limits.

To set the parameters, double click on the selected cell, input the value and press “OK” to confirm it or “Cancel” to exit from the input window.



INSTRUCTION MANUAL DPS (DIGITAL POSITION SYSTEM) QT series (Software)



Parameter Send

Power Limit (min)

0,0 50,0

OK Cancel



Parameter Send

Power Limit (max)

OK Cancel



INSTRUCTION MANUAL DPS (DIGITAL POSITION SYSTEM) QT series (Software)



3.7.4 SIGNAL FAIL MODE

↓		MAIN
↓		SYSTEM INFO
↓		SYSTEM SET UP
↓		CALIBRATION
↓		COMMAND MODE
OK		FAIL & TRIP SETTING
	↓	SOV CONFIGURATION
	↓	POS.EXCESS FAIL MODE
	↓	POWER FAIL MODE
OK		SIGNAL FAIL MODE
	ESC	To return to menu

This command allows to configure the minimum and maximum admissible inlet signal (mA), the actions to be executed if these limits are reached and the error clearing condition.

Selecting the option the following menu is displayed:



```
ERROR MODE OFF
END MODE AUTO
SIGNAL LIMIT
ACTUATOR POSITION
```

On the PC, it's possible to configure all the selections and values in the "Signal fail" panel located in "FAILS CFG" tag.



SIGNAL FAIL

Mode Ack

min max

Limits [mA]

Position [%]



INSTRUCTION MANUAL DPS (DIGITAL POSITION SYSTEM) QT series (Software)



3.7.4.1 ERROR MODE

The first line allows to configure the action to be executed in case of an out of range or fail signal. The selection can be made by selecting the line with the up / down buttons and scrolling the options by pushing the OK key. The available options and relevant actions are:



OPTION	APPLICABILITY	EXECUTED ACTION
OFF	All cases	Nothing
SAFETY SD1	At least one solenoid valve available	The actuator goes to the "SAFETY SD1" position corresponding to the "SAFETY SD1" SOV configuration.
SAFETY SD2	At least two solenoid valves available	The actuator goes to the "SAFETY SD2" position corresponding to the "SAFETY SD2" SOV configuration.
SAFETY SD3	Three solenoid valves available	The actuator goes to the "SAFETY SD3" position corresponding to the "SAFETY SD3" SOV configuration.
SPOOL	All cases	The actuator is driven to a specific position using the spool (see actuator position).
FREEZE	All cases	Actuator freezes in last position.
WARNING	All cases	On the positioner display will be shown a warning message

On the PC, it's possible to configure the signal error mode.

To set the value, double click on the corresponding cell, click the option and press "Send" to confirm it or "Abort" to exit.





INSTRUCTION MANUAL DPS (DIGITAL POSITION SYSTEM) QT series (Software)



3.7.4.2 END MODE

The end mode option configures the action to be executed at the end of the error conditions. The selection can be made by selecting the line with the up / down buttons and scrolling the options by pushing the OK key. The available options are:



OPTION	EXECUTED ACTION
AUTO	Automatic return to normal working condition without waiting for confirmation.
WAIT ACK	A confirmation is required before returning to normal working condition.
WAIT NOERR	Automatic return to normal working condition only if all error conditions have been cleared.

On the PC, it is possible to choose the power end mode selecting the option on the corresponding pull-down menu.

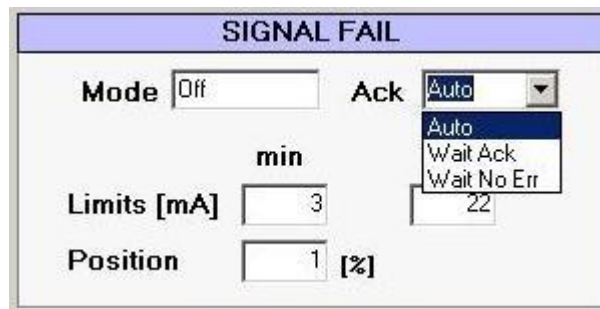

3.7.4.3 SIGNAL LIMIT

A list with high and low signal limit values is displayed:



```
SIGN.LIMIT LOW 3.0
SIGN.LIMIT HIGH 22.0
```

Selecting the first line, it is possible to modify the low limit, using the and keys and the OK button to confirm.



```
SIGN. LIMIT LOW
3.0
PRESS OK TO CONFIRM
```

For upper signal limit, the displayed message is:



```
SIGN. LIMIT HIGH
22.0
PRESS OK TO CONFIRM
```

On the PC, it is possible to configure all the values in the "Signal fail" panel. To set the value, double click on the selected cell, input the value and press "OK" to confirm it or "Cancel" to exit from the input window.



INSTRUCTION MANUAL DPS (DIGITAL POSITION SYSTEM) QT series (Software)



Parameter Send

Signal Error Limit (min)

0,0 10,0

OK Cancel



Parameter Send

Signal Error Limit (max)

OK Cancel

3.7.4.4 ACTUATOR POSITION

This function is active only if the “Spool” selection has been made for the “Error mode” option; by this function it's possible to define the actuator position in case of signal fail.



ACTUATOR POSITION
1.0 %
PRESS OK TO CONFIRM

The value of the position (expressed in percentage of the stroke) can be adjusted between -10 and 110% of the stroke, by pressing the ↑ and ↓ keys and subsequently confirmed with the OK key.

To set the value, on the PC, double click on the corresponding cell, input the value and press “OK” to confirm it or “Cancel” to exit from the input window.



INSTRUCTION MANUAL DPS (DIGITAL POSITION SYSTEM) QT series (Software)

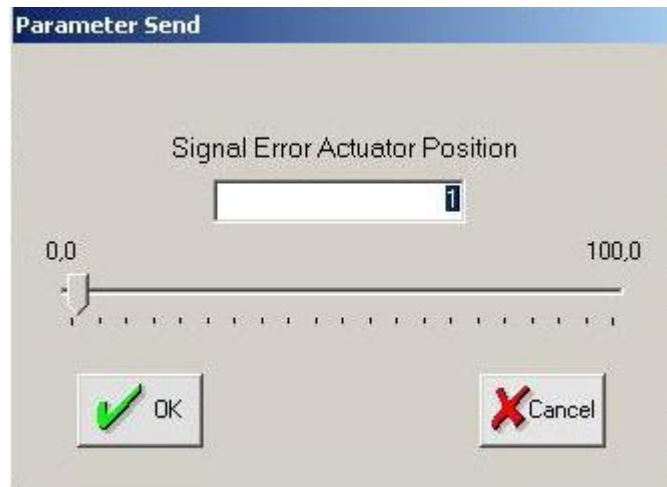

3.7.5 PRESSURE FAIL MODE

↓			MAIN
↓			SYSTEM INFO
↓			SYSTEM SET UP
↓			CALIBRATION
↓			COMMAND MODE
OK			FAIL & TRIP SETTING
	↓		SOV CONFIGURATION
	↓		POS.EXCESS FAIL MODE
	↓		POWER FAIL MODE
	↓		SIGNAL FAIL MODE
	OK		PRESSURE FAIL MODE
		ESC	To return to menu

This command allows to configure the minimum admissible supply pressure value.

The following menu is displayed:



```

ERROR MODE OFF
END MODE AUTO
PRESS. LIMIT 5.0 Bar
  
```

On the PC, it is possible to configure all the selections and values in the “Pressure fail” panel located in “FAILS CFG” tag.

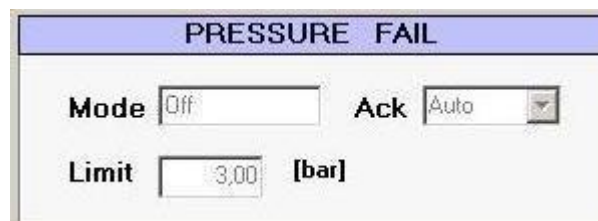

3.7.5.1 ERROR MODE

The first line allows to configure the action to be executed in case of supply pressure error. The selection can be made by selecting the line with the up / down buttons and scrolling the options by pushing the OK key. The available options are:



OPTION	APPLICABILITY	EXECUTED ACTION
OFF	All cases	Nothing
SAFETY SD1	At least one solenoid valve available	The actuator goes to the "SAFETY SD1" position corresponding to the "SAFETY SD1" SOV configuration.
SAFETY SD2	At least two solenoid valves available	The actuator goes to the "SAFETY SD2" position corresponding to the "SAFETY SD2" SOV configuration.
SAFETY SD3	Three solenoid valves available	The actuator goes to the "SAFETY SD3" position corresponding to the "SAFETY SD3" SOV configuration.
WARNING	All cases	On the positioner display will be shown a warning message

On the PC, it's possible to configure the pressure error mode.
To set the value, double click on the corresponding cell, click the option and press "SEND" to confirm it or "ABORT" to exit.



3.7.5.2 END MODE

The end mode option allows to configure the action to be executed at the end of the error conditions. The selection can be made by selecting the line with the up / down buttons and scrolling the options by pushing the OK key. The available options are:



OPTION	EXECUTED ACTION
AUTO	Automatic return to normal working condition without waiting for confirmation.
WAIT ACK	A confirmation is required before returning to normal working condition.
WAIT NOERR	Automatic return to normal working condition only if all error conditions have been cleared.

On the PC, it is possible to choose the pressure end mode selecting the option on the corresponding pull-down menu.



INSTRUCTION MANUAL DPS (DIGITAL POSITION SYSTEM) QT series (Software)



3.7.5.3 PRESSURE LIMIT

This option allows to set the minimum admissible supply pressure value (Psi or bar).



PRESS. LIMIT
5.00 Bar
PRESS OK TO CONFIRM

The input pressure value can be selected in a range of 0÷150 Psi or 0÷10 bar, using the and keys. OK button confirmation is required.

On the PC, it is possible to modify the pressure limit.

To set the value, double click on the selected cell, input the value and press “OK” to confirm it or “Cancel” to exit from the input window.

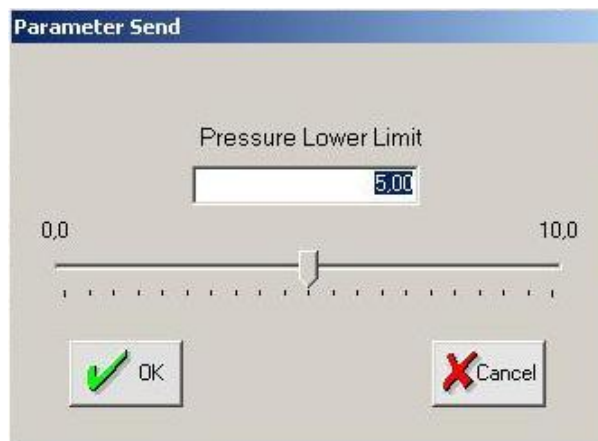

3.7.6 PROBE FAIL

NEW FUNCTION

Starting from DSP release 4.01 is available ONLY on PC software the Probe fail error configuration.

To configure this error refer to Probe Fail window located in “FAILS CFG” tag.

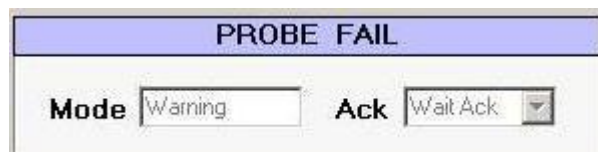

3.7.6.1 PROBE FAIL ERROR MODE

On PC software is possible to configure the error mode double clicking on Probe Fail area and select the related function. The available options are:



INSTRUCTION MANUAL DPS (DIGITAL POSITION SYSTEM) QT series (Software)



OPTION	APPLICABILITY	EXECUTED ACTION
OFF	All cases	Nothing
SAFETY SD1	At least one solenoid valve available	The actuator goes to the "SAFETY SD1" position corresponding to the "SAFETY SD1" SOV configuration.
SAFETY SD2	At least two solenoid valves available	The actuator goes to the "SAFETY SD2" position corresponding to the "SAFETY SD2" SOV configuration.
SAFETY SD3	Three solenoid valves available	The actuator goes to the "SAFETY SD3" position corresponding to the "SAFETY SD3" SOV configuration.
WARNING	All cases	On the positioner display will be shown a warning message



3.7.6.2 PROBE FAIL END MODE

The end mode option allows to configure the action to be executed at the end of the error conditions.. The available options are:

OPTION	EXECUTED ACTION
AUTO	Automatic return to normal working condition without waiting for confirmation.
WAIT ACK	A confirmation is required before returning to normal working condition.
WAIT NOERR	Automatic return to normal working condition only if all error conditions have been cleared.

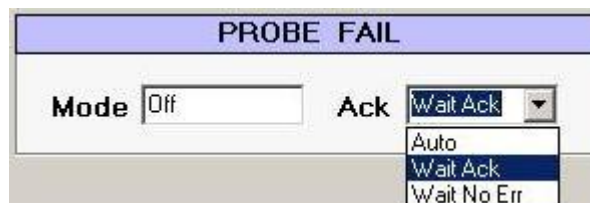

3.7.7 TRIPS MODE (for trip 1, 2, 3, 4)

↓			MAIN
↓			SYSTEM INFO
↓			SYSTEM SET UP
↓			CALIBRATION
↓			COMMAND MODE
OK			FAIL & TRIP SETTING
	↓		SOV CONFIGURATION

	↓		POS.EXCESS FAIL MODE
	↓		POWER FAIL MODE
	↓		SIGNAL FAIL MODE
	↓		PRESSURE FAIL MODE
	OK		MODE FOR TRIP1-4
		ESC	To return to menu

This option allows to configure the position of the actuator when the trip 1 (or 2, 3, 4) is fired, the actions to be executed and the trip clearing condition.

With the selection of one of the available trips, the displayed menu is:



```

ERROR MODE OFF
END MODE AUTO
ACTUATOR POSITION
ON STATUS NOT ENERG.
  
```

On the PC, all these options could be configured from the "Trips" panel located in main window.



FAIL / TRIP SETTINGS					
	Mode	Pos.	Ack	On St.	Err Hw
1	SSD1	0	Auto	E	● ●
2	Off	0	Auto	nE	● ●
3	Off	0	Auto	nE	● ●
4	Off	0	Auto	nE	● ●

3.7.7.1 ERROR MODE

The first line allows to configure the action to be executed in case of trip signal, the selection can be made by selecting the line with the up / down buttons and scrolling the options by pushing the OK key. The available options are:



OPTION	APPLICABILITY	EXECUTED ACTION
OFF	All cases	Nothing
SAFETY SD1	At least one solenoid valve available	The actuator goes to the "SAFETY SD1" position corresponding to the "SAFETY SD1" SOV configuration.
SAFETY SD2	At least two solenoid valves available	The actuator goes to the "SAFETY SD2" position corresponding to the "SAFETY SD2" SOV configuration.
SAFETY SD3	Three solenoid valves available	The actuator goes to the "SAFETY SD3" position corresponding to the "SAFETY SD3" SOV configuration.
SPOOL	All cases	The actuator is driven to a specific position using the spool (see actuator position).
FREEZE	All cases	Actuator freezes in last position.
ACK	All cases	Trip is used for the error acknowledgment in remote mode.
EXTERNAL SOV	All cases	External safety shut down valve has been activated.
WARNING	All cases	On the positioner display will be shown a warning message



INSTRUCTION MANUAL DPS (DIGITAL POSITION SYSTEM) QT series (Software)



On the PC, it's possible to configure the signal error mode.

To set the value, double click on the corresponding cell, click the option and press "SEND" to confirm it or "ABORT" to exit.



3.7.7.2 END MODE

The end mode option allows to configure the action to be executed at the end of the error conditions, the selection can be made by selecting the line with the up / down buttons and scrolling the options by pushing the OK key. The available options are:



OPTION	EXECUTED ACTION
AUTO	Automatic return to normal working condition without waiting for confirmation.
WAIT ACK	A confirmation is required before returning to normal working condition.
WAIT NOERR	Automatic return to normal working condition only if all error conditions have been cleared.

On the PC, it is possible to choose the trip end mode, selecting the option on the corresponding pull-down menu.



3.7.7.3 ACTUATOR POSITION

This function is active only if the "Spool" selection has been made for the "Error mode" option; it allows to define the position of the actuator in case of trip.



INSTRUCTION MANUAL DPS (DIGITAL POSITION SYSTEM) QT series (Software)



ACTUATOR POSITION
1.0 %
PRESS OK TO CONFIRM

The value of the position (expressed in percentage of the stroke) can be adjusted between -10 and 110% of the stroke, by pressing the ↑ and ↓ keys and subsequently confirmed with the OK key.

To set the value, on the PC, double click on the corresponding cell, input the value and press “OK” to confirm it or “Cancel” to exit from the input window.



3.7.7.4 ON STATUS

This option allows to configure the ON status for the selected trip; the changing can be made by selecting the line with the up / down buttons and scrolling the options by pushing the OK key. The available options are:



OPTION		DESCRIPTION
E	= ENERGIZED	ON Status = Energized. Corresponds to “1” state.
nE	= NOT ENERG.	ON Status = NOT Energized. Corresponds to “0” state.

On the PC, it is possible to choose the trip ON status, selecting the option on the corresponding pull-down menu.



FAIL / TRIP SETTINGS						
	Mode	Pos.	Ack	On St.	Err	Hw
1	SSD1	0	Auto	E	●	●
2	Off	0	Auto	nE	●	●
3	Off	0	Auto	E	●	●
4	Off	0	Auto	nE	●	●

3.8 GENERAL SETTING

↓			MAIN
↓			SYSTEM INFO
↓			SYSTEM SET UP
↓			CALIBRATION
↓			COMMAND MODE
↓			FAIL & TRIP SETTING
OK			GENERAL SETTING
	ESC		To return to main menu

This menu allows to customize the system.

The displayed menu is:



MEASUR UNITS **MET/IMP**
 LANGUAGE **ENGLISH**
 DATE & TIME
 PASSWORD
 CONTRAST

On the PC, only some of these data are available into the “General setting” panel located in CFG tag.

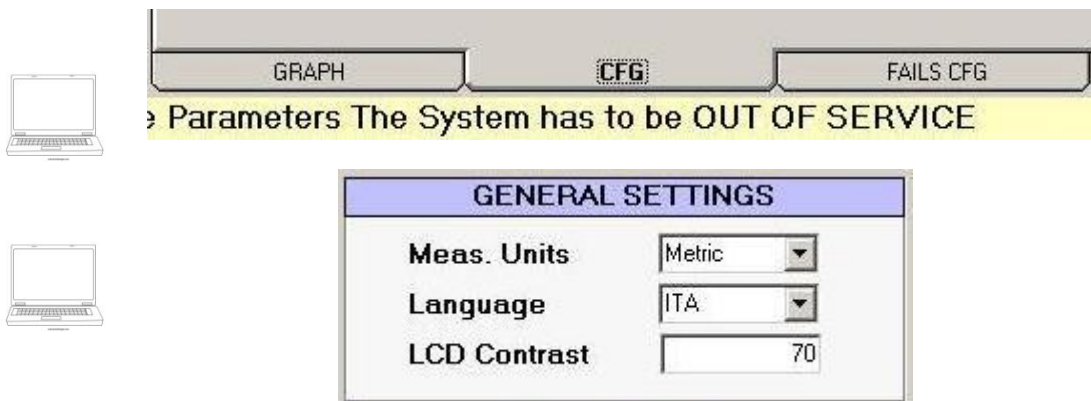

The password login and changing are available in the main command line (pull-down password menu).



3.8.1 MEASUREMENTS UNITS

↓			MAIN
↓			SYSTEM INFO
↓			SYSTEM SET UP
↓			CALIBRATION
↓			COMMAND MODE
↓			FAIL & TRIP SETTING
OK			GENERAL SETTING
	OK		MEASUR UNITS
		ESC	To return to menu

This command allows to configure the measurement units system used to display the variables.

The configuration can be made by selecting the line with the up / down buttons, scrolling the options by pushing the OK key and choosing between ISO metrical system (MET) and imperial system (IMP).

VARIABLE	ISO Metrical system	Imperial system
Pressure	bar	Psi
Temperature	°C	°F

On the PC, it is possible to choose the measurement units system, selecting the option on the corresponding pull-down menu.

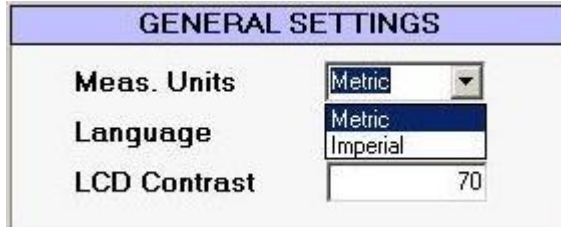

3.8.2 LANGUAGE

↓			MAIN
↓			SYSTEM INFO
↓			SYSTEM SET UP
↓			CALIBRATION
↓			COMMAND MODE
↓			FAIL & TRIP SETTING
OK			GENERAL SETTING
	↓		MEASUR UNITS
	OK		LANGUAGE
		ESC	To return to menu

The available option for the language is English.

3.8.3 DATE AND TIME

↓			MAIN
↓			SYSTEM INFO
↓			SYSTEM SET UP
↓			CALIBRATION
↓			COMMAND MODE
↓			FAIL & TRIP SETTING
OK			GENERAL SETTING
	↓		MEASUR UNITS
	↓		LANGUAGE
	OK		DATE & TIME
		ESC	To return to menu

This option allows to configure the system date and time.



[mm/dd/yyyy]
10 / 03 / 2007
12: 25: 41

Every value can be modified using the up / down buttons and the OK key to confirm it.

On the PC, it is possible to modify the system date and time.

To set the value, double click on the corresponding cells located in CFG tag, input the value and press "SEND" to confirm it or "ABORT" to exit from the input window.



INSTRUCTION MANUAL DPS (DIGITAL POSITION SYSTEM) QT series (Software)

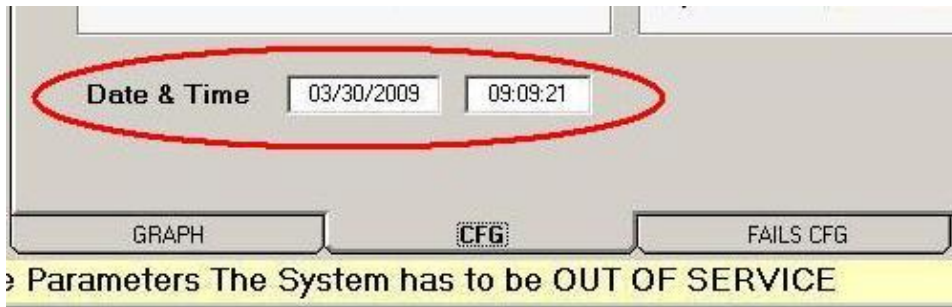

3.8.4 PASSWORD

↓			MAIN
↓			SYSTEM INFO
↓			SYSTEM SET UP
↓			CALIBRATION
↓			COMMAND MODE
↓			FAIL & TRIP SETTING
↓			GENERAL SETTING
OK			MEASUR UNITS
	↓		LANGUAGE
	↓		DATE & TIME
	OK		PASSWORD
		ESC	To return to menu

With this selection, it's possible to change the user password.

The following menu is displayed:



PASSWORD: _ _ _ _ _
CONFIRM: _ _ _ _ _

A sequence of 5 push buttons is required to define the user password, used to enter the system from the local panel (the device is supplied by the manufacturer with the default user password [OK ↑ ↓ ↑ ↓]).
On the PC, a sequence of alfa-numerical digits is required (default is 12345).



INSTRUCTION MANUAL DPS (DIGITAL POSITION SYSTEM) QT series (Software)



3.8.5 CONTRAST

↓			MAIN
↓			SYSTEM INFO
↓			SYSTEM SET UP
↓			CALIBRATION
↓			COMMAND MODE
↓			FAIL & TRIP SETTING
↓			GENERAL SETTING
OK			MEASUR UNITS
	↓		LANGUAGE
	↓		DATE & TIME
	↓		PASSWORD
	↓		CONTRAST
	OK		
		ESC	To return to menu

Selecting this option, it's possible to adjust the contrast of the local control device monitor.



CONTRAST
070

The value can be changed in a range between 1 and 100 using the up / down buttons and can be confirmed by the OK key.

On the PC, it is possible to adjust the contrast from the "General setting" panel.

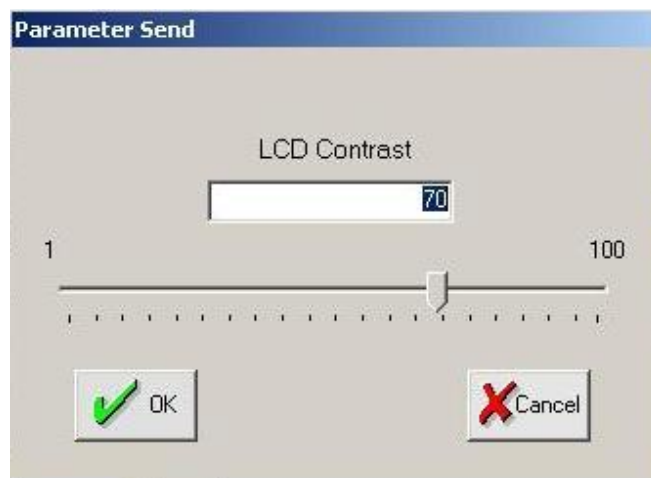

To set the value, double click on the corresponding cell, input the value and press "OK" to confirm it or "Cancel" to exit from the input window.



INSTRUCTION MANUAL DPS (DIGITAL POSITION SYSTEM) QT series (Software)



3.9 SYSTEM DATA

↓		MAIN
↓		SYSTEM INFO
↓		SYSTEM SET UP
↓		CALIBRATION
↓		COMMAND MODE
↓		FAIL & TRIP SETTING
↓		GENERAL SETTING
OK		SYSTEM DATA
	ESC	To return to main menu

This option shows on the local control panel display the values of the electronic board temperature (TE) and the supply power voltage (VI) on the main PCB.



SYSTEM DATA

```
-----
TE    XXX.X C
VI    X:XX V
```

On the PC, these values are displayed in "CFG" tag



The screenshot shows a software interface with several sections. The 'TEMP / POWER' section is highlighted with a red circle and contains the following data:

TEMP / POWER	
TE	28,4 [°C]
VI	40,59 [V]

Other visible sections include 'SD CARD' with 'Pre Trigger Time' (8 [sec]) and 'Log Time' (60 [min]), and 'Date & Time' (04/01/2009 16:35:32). Navigation buttons at the bottom include GRAPH, CFG, and FAILS CFG.



INSTRUCTION MANUAL DPS (DIGITAL POSITION SYSTEM) QT series (Software)



3.10 COMMUNICATION

↓			MAIN
↓			SYSTEM INFO
↓			SYSTEM SET UP
↓			CALIBRATION
↓			COMMAND MODE
↓			FAIL & TRIP SETTING
↓			GENERAL SETTING
↓			SYSTEM DATA
OK			COMMUNICATION
	ESC		To return to main menu

Selecting the only (at the present time) available option in the menu COMMUNICATION, it's possible to enter the HART PROTOCOL 6.0 parameters list.



HART TAG
MESSAGE
DESCRIPTOR
DATE
POLLING ADDRESS 0
DEVICE ID 1

On the PC, these data are available into the "Hart" tag. Note that this tag is displayed only when the software is connected in HART mode



The screenshot shows a software window with several panels:

- HART PARAMETERS:** Contains input fields for Tag (STID8QT3), Date (01/01/2000), Descriptor, Message, Polling Address (0), and Dev. ID (1). A "Poll Device" button is located below these fields.
- HART COMMUNICATION:** Contains a dropdown menu for "HART Mode".
- HART PROTOCOL:** Contains input fields for Long Frame Address (0881000001), Command (33), Response Code (00), Error Code (00), and Device Status (40).
- Navigation:** At the bottom, there are buttons for GRAPH, CFG, HART (which is highlighted), and FAILS CFG.

3.10.1 HART TAG

↓			MAIN
↓			SYSTEM INFO
↓			SYSTEM SET UP
↓			CALIBRATION
↓			COMMAND MODE
↓			FAIL & TRIP SETTING
↓			GENERAL SETTING
↓			SYSTEM DATA
OK			COMMUNICATION
	OK		HART TAG
	ESC		To return to menu

This option allows to display the HART parameter named Tag.



INSTRUCTION MANUAL DPS (DIGITAL POSITION SYSTEM) QT series (Software)



HART TAG
STID881
PRESS ESC/OK TO EXIT

The Tag is a 8 character label assigned by the end user based on the location and use of the field device. It's a 8 character (6 byte) Packed ASCII string used to identify the field device. The term originated when physical tags were attached to instruments for this purpose. It's not possible to modify the Tag parameter by the local user interface.

This operation is possible on the PC, from the "Communication" panel.



To set the value, double click on the corresponding cell, input the value and press "SEND" to confirm it or "ABORT" to exit from the input window.

3.10.2 MESSAGE

↓			MAIN
↓			SYSTEM INFO
↓			SYSTEM SET UP
↓			CALIBRATION
↓			COMMAND MODE
↓			FAIL & TRIP SETTING
↓			GENERAL SETTING
↓			SYSTEM DATA
OK			COMMUNICATION
	↓		HART TAG
	OK		MESSAGE
		ESC	To return to menu

This option allows to display the HART parameter named Message.



MESSAGE
...first 16 chars
...second 16 chars
PRESS ESC/OK TO EXIT

The Message is a 32 character (24 byte) Packed ASCII string used by the Master for record keeping. The default value is a blanked string, 32 bytes long. It's not possible to modify the Message parameter by the local user interface.

This operation is possible on the PC, from the "Communication" panel.



INSTRUCTION MANUAL DPS (DIGITAL POSITION SYSTEM) QT series (Software)



To set the value, double click on the corresponding cell, input the value and press “SEND” to confirm it or “ABORT” to exit from the input window.

3.10.3 DESCRIPTOR

↓			MAIN
↓			SYSTEM INFO
↓			SYSTEM SET UP
↓			CALIBRATION
↓			COMMAND MODE
↓			FAIL & TRIP SETTING
↓			GENERAL SETTING
↓			SYSTEM DATA
OK			COMMUNICATION
	↓		HART TAG
			MESSAGE
	OK		DESCRIPTOR
		ESC	To return to menu

This option allows to display the HART parameter named Descriptor.



DESCRIPTOR
.....16 chars
PRESS ESC/OK TO EXIT

The Descriptor is a 16 character (12 byte) Packed ASCII string used by the Master for record keeping. The default value is a blanked string, 16 bytes long. It's not possible to modify the Descriptor parameter by the local user interface.

This operation is possible on the PC, from the “Communication” panel.



To set the value, double click on the corresponding cell, input the value and press “SEND” to confirm it or “ABORT” to exit from the input window.



INSTRUCTION MANUAL DPS (DIGITAL POSITION SYSTEM) QT series (Software)



3.10.4 DATE

↓			MAIN
↓			SYSTEM INFO
↓			SYSTEM SET UP
↓			CALIBRATION
↓			COMMAND MODE
↓			FAIL & TRIP SETTING
↓			GENERAL SETTING
↓			SYSTEM DATA
OK			COMMUNICATION
	↓		HART TAG
	↓		MESSAGE
	↓		DESCRIPTOR
	OK		DATE
		ESC	To return to menu

This option allows to display and/or modify the HART parameter named Date.



```
DATE [mm/dd/yyyy]
05/29/2006
PRESS ESC TO EXIT
```

The date is represented by three 8-bit binary unsigned integers representing, respectively, the day, month and year (minus 1900). It's a date code, used by the Master for record keeping (e.g. last or next calibration date). In this page, the 4 provided keys are OK, ↑, ↓ and ESC and they have the following function:
OK key allows to shift from a field to another one of the page or in clockwise direction from day to month and to year.

Key ↑ once pointed out the interest field, the current value is allowed to increase according to the field standards (ex.: day field including between 1 and 31);
Key ↓ once pointed out the concern field, the current value is allowed to decrease according to the field standards (ex.: month field including between 1 and 12);
The ESC key allows to return to the Hart Protocol submenu.

On the PC, it is possible to modify the Date parameter from the "Communication" panel.



To set the value, double click on the corresponding cell, input the value and press "SEND" to confirm it or "ABORT" to exit from the input window.

3.10.5 POLLING ADDRESS

↓			MAIN
↓			SYSTEM INFO
↓			SYSTEM SET UP
↓			CALIBRATION
↓			COMMAND MODE
↓			FAIL & TRIP SETTING
↓			GENERAL SETTING
↓			SYSTEM DATA
OK			COMMUNICATION
	↓		HART TAG
	↓		MESSAGE
	↓		DESCRIPTOR
	↓		DATE

	OK		POLLING ADDRESS
		ESC	To return to menu

This option allows to display and/or modify the HART parameter named Polling Address.



POLLING ADDRESS
00
PRESS OK TO CONFIRM

In the HART Protocol, the polling address is an integer used to identify the field device. It is used to construct the Short Frame Address. The Polling Address is set to 0 in point to point installations.

The 4 keys provided in this page have the following function:

- Key ↑ allows to increase the current value of polling address within a foreseen range from 0 and 15;
- Key ↓ allows to decrease the current value of polling address, within a foreseen range from 0 and 15;
- OK key confirms the defined polling address and allows to return to the submenu Hart Protocol.
- ESC key cancels any current modification phase and allows to return to the Hart Protocol submenu.

On the PC, it is possible to modify the Polling Address from the “Communication” panel.

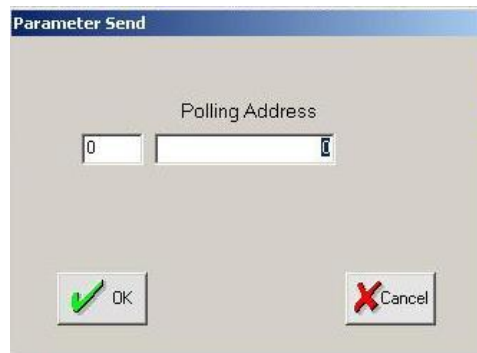

To set the value, double click on the corresponding cell, input the value and press “SEND” to confirm it or “ABORT” to exit from the input window.

The master usually reaches the devices, starting from polling address equal to 0.

In multi-drop installations all the field devices are generally configured to a different polling address to allow automatic identification by the master.

Using the “Poll” command button, it’s possible to identify a device having the polling address not equal to 0.

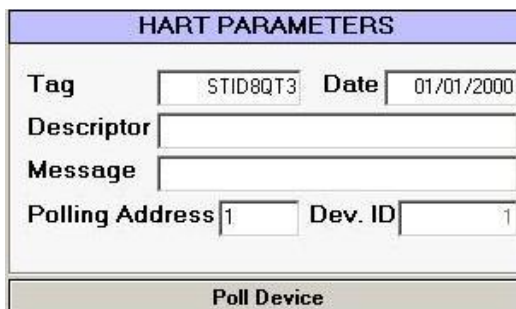



INSTRUCTION MANUAL DPS (DIGITAL POSITION SYSTEM) QT series (Software)



3.10.6 DEVICE ID

↓		MAIN
↓		SYSTEM INFO
↓		SYSTEM SET UP
↓		CALIBRATION
↓		COMMAND MODE
↓		FAIL & TRIP SETTING
↓		GENERAL SETTING
↓		SYSTEM DATA
OK		COMMUNICATION
	↓	HART TAG
	↓	MESSAGE
	↓	DESCRIPTOR
	↓	DATE
	↓	POLLING ADDRESS
OK		DEVICE ID
	ESC	To return to menu

This option allows to display the HART parameter named Device ID (integer number).

This number is different for every device manufactured with a given Manufacturer ID and Device Type. It returned in bytes 9-11 of Identity Commands and for the QuickTrak III it coincides with the system serial number (Part Number).

It's not possible to modify the Device ID parameter by the local user interface or by remote; this value changes if the Part Number parameter is modified. See chapter ADVANCED for details.



HART PARAMETERS			
Tag	<input type="text" value="STID8QT3"/>	Date	<input type="text" value="01/01/2000"/>
Descriptor	<input type="text"/>		
Message	<input type="text"/>		
Polling Address	<input type="text" value="1"/>	Dev. ID	<input type="text" value="1"/>
Poll Device			



INSTRUCTION MANUAL DPS (DIGITAL POSITION SYSTEM) QT series (Software)



3.11 DIAGNOSTIC

↓			MAIN
↓			SYSTEM INFO
↓			SYSTEM SET UP
↓			CALIBRATION
↓			COMMAND MODE
↓			FAIL & TRIP SETTING
↓			GENERAL SETTING
↓			SYSTEM DATA
↓			COMMUNICATION
OK			DIAGNOSTIC
	ESC		To return to main menu

This option allows to display the system diagnostic information.

The following sub menu is displayed:



```

STROKE KM   XXXXXX.XX
IN SVC HOURS XXXXXX.XX
MIN TEMP.   XXX.XC
MAX TEMP.   XXX.XC
AVER.TEMP.  XXX.XC
PERM. TIME
dP UP-DOWN
ERROR STAT
CALIB STAT
OUT SVC STAT
IN SVC STAT
STAT FREQ
    
```

with some data directly available:

```

STROKE KM   XXXXXX.XX
IN SVC HOURS XXXXXX.XX
MIN TEMP.   XXX.XC
MAX TEMP.   XXX.XC
AVER.TEMP.  XXX.XC
    
```

where:

- STROKE KM is the total distance covered by the stem (piston) expressed in [km]
- IN SVC HOURS the total time of working [h]
- MIN TEMP. is the minimum temperature reached during the use
- MAX TEMP. is the maximum temperature reached during the use
- AVER.TEMP is the average temperature during the use

On the PC, pushing the “History And Diagnostic” button located in main page:





INSTRUCTION MANUAL DPS (DIGITAL POSITION SYSTEM) QT series (Software)



It's possible to display the system diagnostic data page:

The screenshot shows a software interface with several panels:

- ALARM COUNTERS (Left):** A table with columns 'Counter' and 'Last Date'. Trip 1 is set to 1 with a date of 04/01/2009 14:59:51. Other counters are at 0.
- ALARM COUNTERS (Middle):** A table with columns 'Counter' and 'Last Date'. All counters (Free 5, Calibr. Aborted, etc.) are at 0.
- SYSTEM COUNTERS (Middle):** A table with columns 'Counter' and 'Last Date'. Calibration, Out Service, and In Service are all at 0.
- POSITION DATA FROM FIRST STARTUP (Middle):** A table showing times for various strokes (0.1, 1.25, 25.50, 50.75, 75.99, 99.100) in hours, minutes, and seconds.
- IN SERVICE (Middle):** A table with 'In Service Time' at 0h 00m 00s.
- EVENT LOG (Right):** A list of system events with timestamps and descriptions, such as '04/01/2009 17:21:47 PRM: Part Number (Dev.ID): 1 -> 1'.
- Max Delta Pressure (bar) (Right):** A table with columns 'Up' and 'Down' for various pressure points.
- TEMPERATURE (C) (Right):** A table showing Min (24.3), Max (33.0), and Average (27.7) temperatures.

From this page, press the “Download” command button to read or refresh the system diagnostic data. Press the “Report” command button to save the data in RTF format.

NEW FUNCTION

Starting from Release 4.01 the event log function is implemented. It's possible to configure the event that have to be displayed and using the buttons under the EVENT LOG window it's possible to start or stop the reading. Event log data are included in report file.

Diagnostic Report

Report Date: 01/04/2009 17.43

Alarm	Counter	Date
Trip 1	: 1	04/01/2009 14:59:51
Trip 2	: 0	
Trip 3	: 0	
Trip 4	: 0	
Pressure	: 0	
Signal <min	: 0	
Signal >max	: 0	
Pos.Exc.Error:	0	
Pos.Exc.Warn.:	0	
Probe	: 1	04/01/2009 12:52:14
Power <min	: 0	
Hard Limits	: 0	
DSP Timeout	: 0	
Watch Dog	: 0	
Power >max	: 0	
Error On SOV 1:	0	



INSTRUCTION MANUAL DPS (DIGITAL POSITION SYSTEM) QT series (Software)



Error On SOV 2: 0
Error On SOV 3: 0
DSP Restart : 0
Calib. Erased: 0
EEPROM 0 : 0
EEPROM 1 : 0
HC12 Restart : 0
EEPROMEXT 0 : 0
EEPROMEXT 1 : 0
Free 1 : 0
Free 2 : 0
Free 3 : 0
Free 4 : 0
Free 5 : 0
Calibr. Aborted: 0
0-Spool Error: 0
0-Spool Search: 0
Spool Limit : 0
Friction Warn.: 0
Encoder : 0
Friction Error: 0
Index 1 : 0
Index 2 : 0

System	Counter	Date
Calibration :	0	
Out Service :	0	
In Service :	0	

TEMPERATURE (C)
Min : 24.3
Max : 33.0
Average: 27.7

In Service Time: 0h 00m 00s
Total Stroke (m): 0

Time in [0,1) : 3h 46m 10s
Time in [1,25) : 0h 00m 00s
Time in [25,50): 0h 00m 00s
Time in [50,75): 0h 00m 00s
Time in [75,99): 0h 00m 00s
Time in [99,100): 0h 00m 00s

Max Delta Pressure (bar)
[1,25) Up: 0.00 Down: 0.00
[25,50) Up: 0.00 Down: 0.00
[50,75) Up: 0.00 Down: 0.00
[75,99) Up: 0.00 Down: 0.00

Events Log
04/01/2009 17:21:47 PRM: Part Number (Dev.ID): 1 -> 1
04/01/2009 15:01:51 PRM: SOV Number: 1 -> 3
04/01/2009 14:59:54 No Errors
04/01/2009 14:59:53 PRM: Trips ON St.: nE nE nE nE ->



INSTRUCTION MANUAL DPS (DIGITAL POSITION SYSTEM) QT series (Software)



```

E nE nE nE
04/01/2009 14:59:51 Trip 1
04/01/2009 14:59:51 PRM: Trip 1 Fail Mode: Off -> SSD1
04/01/2009 13:19:30 PRM: Power Fail Mode: Off -> Off
04/01/2009 12:56:05 PRM: Pos.Exc.Err.Mode: Off -> Off
04/01/2009 12:52:53 No Errors
04/01/2009 12:52:52 PRM: Probe. Fail Mode: SSD1 -> Off
04/01/2009 12:52:14 Probe Error
04/01/2009 12:52:13 System startup
04/01/2009 12:48:59 EEPROMEXT0 Error
04/01/2009 12:48:59 EEPROM Global Reset
04/01/2009 12:48:59 EEPROMEXT Global Reset

```

3.11.1 PERM. TIME

↓			MAIN
↓			SYSTEM INFO
↓			SYSTEM SET UP
↓			CALIBRATION
↓			COMMAND MODE
↓			FAIL & TRIP SETTING
↓			GENERAL SETTING
↓			SYSTEM DATA
↓			COMMUNICATION
OK			DIAGNOSTIC
	↓		STROKE KM
	↓		IN SVC HOURS
	↓		MIN TEMP.
	↓		MAX TEMP.
	↓		AVER.TEMP.
	OK		PERM. TIME
		ESC	To return to menu

With this selection, it is possible to know the permanence time in defined range of the stroke. The stroke range expressed in percent of the stroke are the following:

- 0 ÷ 1
- 1 ÷ 25
- 25 ÷ 50
- 50 ÷ 75
- 75 ÷ 99
- 99 ÷ 100

On the local control panel display the values expressed in hours are shown as it follows:



```

0-1 XXXXXXXX.XXh
1-25 XXXXXXXX.XXh
25-50 XXXXXXXX.XXh
50-75 XXXXXXXX.XXh
75-99 XXXXXXXX.XXh
99-100 XXXXXXXX.XXh

```

With ESC command, it is possible to return to the diagnostic menu.



INSTRUCTION MANUAL DPS (DIGITAL POSITION SYSTEM) QT series (Software)



On the PC, those values are available in the diagnostic page:



POSITION DATA FROM FIRST STARTUP	
Total Stroke (m)	0
Time in [0,1)	3h 46m 10s
Time in [1,25)	0h 00m 00s
Time in [25,50)	0h 00m 00s
Time in [50,75)	0h 00m 00s
Time in [75,99)	0h 00m 00s
Time in [99,100)	0h 00m 00s

3.11.2 dP UP-DOWN

↓			MAIN
↓			SYSTEM INFO
↓			SYSTEM SET UP
↓			CALIBRATION
↓			COMMAND MODE
↓			FAIL & TRIP SETTING
↓			GENERAL SETTING
↓			SYSTEM DATA
↓			COMMUNICATION
OK			DIAGNOSTIC
	↓		STROKE KM
	↓		IN SVC HOURS
	↓		MIN TEMP.
	↓		MAX TEMP.
	↓		AVER.TEMP.
	↓		PERM. TIME
	OK		dP UP-DOWN
		ESC	To return to menu

This selection shows the difference of actuator chamber pressure in each sector of the stroke for extending and retracting stem stroke.

On the local control panel the values are shown as below:



dP UP-DOWN Bar (or PSI)

```

-----
1-25  XX.XX XX.XX
25-50  XX.XX XX.XX
50-75  XX.XX XX.XX
75-99  XX.XX XX.XX
    
```

With ESC command, it is possible to return to the diagnostic menu.

On the PC, those values are available in the diagnostic page:



Max Delta Pressure (bar)		
	Up	Down
[1,25)	0,00	0,00
[25,50)	0,00	0,00
[50,75)	0,00	0,00
[75,99)	0,00	0,00



INSTRUCTION MANUAL DPS (DIGITAL POSITION SYSTEM) QT series (Software)



3.11.3 ERROR STAT

↓			MAIN
↓			SYSTEM INFO
↓			SYSTEM SET UP
↓			CALIBRATION
↓			COMMAND MODE
↓			FAIL & TRIP SETTING
↓			GENERAL SETTING
↓			SYSTEM DATA
↓			COMMUNICATION
OK			DIAGNOSTIC
	↓		STROKE KM
	↓		IN SVC HOURS
	↓		MIN TEMP.
	↓		MAX TEMP.
	↓		AVER.TEMP.
	↓		PERM. TIME
	↓		dP UP-DOWN
	OK		ERROR STAT
		ESC	To return to menu

In this menu the error quantity, the date and time of the last error occurred are stored for each event.

Inside this menu the following error events are listed:



- TRIP1
- TRIP2
- TRIP3
- TRIP4
- PRESSURE FAIL
- LOW SIGNAL FAIL
- HIGH SIGNAL FAIL
- POS. EXCESS ERROR
- POS. EXCESS WARNING
- PROBE ERROR
- LOW POWER FAIL
- HARD LIMITS ERROR
- DSP TIMEOUT
- WATCH DOG ERROR
- HIGH POWER FAIL
- ERROR ON SOV1
- ERROR ON SOV2
- ERROR ON SOV3
- DSP RESTART
- CALIBRATION ERASED
- FREE 1
- FREE 2
- FREE 3
- FREE 4
- FREE 5
- ENCODER ERROR
- EXC. FRICTION ERROR
- INDEX1 NOT FOUND ERR
- INDEX2 NOT FOUND ERR

The selection can be made by selecting the line with the up / down buttons and pushing the OK key.

Once selected the event, the error counter and the last error date are shown:



TITLE (it is the selected variable in the previous list)

COUNTER: XXXXXXXXXXXX
LAST DATE: mm/dd/yyyy
hh:mm:ss



INSTRUCTION MANUAL DPS (DIGITAL POSITION SYSTEM) QT series (Software)



Press ESC or OK to return to the previous menu.

On the PC, the values are shown as below:



ALARM COUNTERS		
	Counter	Last Date
Trip 1	1	04/01/2009 14:59:51
Trip 2	0	
Trip 3	0	
Trip 4	0	
Pressure	0	
Signal <min	0	
Signal >max	0	
Pos.Exc.Error	0	
Pos.Exc.Warn.	0	
Probe	1	04/01/2009 12:52:14
Power <min	0	
Hard Limits	0	
DSP Timeout	0	
Watch Dog	0	
Power >max	0	
Error On SOV 1	0	
Error On SOV 2	0	
Error On SOV 3	0	
DSP Restart	0	
Calib. Erased	0	
EEPROM 0	0	
EEPROM 1	0	
HC12 Restart	0	
EEPROMEXT 0	0	
EEPROMEXT 1	0	
Free 1	0	
Free 2	0	
Free 3	0	
Free 4	0	



INSTRUCTION MANUAL DPS (DIGITAL POSITION SYSTEM) QT series (Software)



ALARM COUNTERS		
	Counter	Last Date
Free 5	0	
Calibr. Aborted	0	
0-Spool Error	0	
0-Spool Search	0	
Spool Limit	0	
Friction Warn.	0	
Encoder	0	
Friction Error	0	
Index 1	0	
Index 2	0	

3.11.4 CALIB STAT

↓		MAIN
↓		SYSTEM INFO
↓		SYSTEM SET UP
↓		CALIBRATION
↓		COMMAND MODE
↓		FAIL & TRIP SETTING
↓		GENERAL SETTING
↓		SYSTEM DATA
↓		COMMUNICATION
OK		DIAGNOSTIC
	↓	STROKE KM
	↓	IN SVC HOURS
	↓	MIN TEMP.
	↓	MAX TEMP.
	↓	AVER. TEMP.
	↓	PERM. TIME
	↓	dP UP-DOWN
	↓	ERROR STAT
OK		CALIB STAT
	ESC	To return to menu

This selection shows the operator the statistical information about the instrument calibration routine (calibration number and last date).

On the local control panel the following values are shown:



```

CALIBRATION
-----
COUNTER: XXXXXXXXXX
LAST DATE: mm/dd/yyyy
hh:mm:ss
    
```

Press ESC or OK to return to the diagnostic menu.

On the PC, the values are shown as below:



SYSTEM COUNTERS		
	Counter	Last Date
Calibration	0	
Out Service	0	
In Service	0	



INSTRUCTION MANUAL DPS (DIGITAL POSITION SYSTEM) QT series (Software)



3.11.5 OUT SVC STAT

↓			MAIN
↓			SYSTEM INFO
↓			SYSTEM SET UP
↓			CALIBRATION
↓			COMMAND MODE
↓			FAIL & TRIP SETTING
↓			GENERAL SETTING
↓			SYSTEM DATA
↓			COMMUNICATION
OK			DIAGNOSTIC
	↓		STROKE KM
	↓		IN SVC HOURS
	↓		MIN TEMP.
	↓		MAX TEMP.
	↓		AVER.TEMP.
	↓		PERM. TIME
	↓		dP UP-DOWN
	↓		ERROR STAT
	↓		CALIB STAT
OK			OUT SVC STAT
	ESC		To return to menu

This selection shows the operator the statistical information about the “out of service” system state (counter and last date).

On the local control panel, the following data are shown:



OUT SVC

COUNTER: XXXXXXXXXX
LAST DATE: mm/dd/yyyy
hh:mm:ss

Press ESC or OK, to return to the diagnostic menu.

On the PC, the values are shown as below:



SYSTEM COUNTERS		
	Counter	Last Date
Calibration	0	
Out Service	0	
In Service	0	

3.11.6 IN SVC STAT

↓			MAIN
↓			SYSTEM INFO
↓			SYSTEM SET UP
↓			CALIBRATION
↓			COMMAND MODE
↓			FAIL & TRIP SETTING
↓			GENERAL SETTING
↓			SYSTEM DATA
↓			COMMUNICATION
OK			DIAGNOSTIC
	↓		STROKE KM
	↓		IN SVC HOURS
	↓		MIN TEMP.
	↓		MAX TEMP.
	↓		AVER.TEMP.
	↓		PERM. TIME



INSTRUCTION MANUAL DPS (DIGITAL POSITION SYSTEM) QT series (Software)



	↓		dP UP-DOWN
	↓		ERROR STAT
	↓		CALIB STAT
	↓		OUT SVC STAT
	OK		IN SVC STAT
		ESC	To return to menu

This selection shows the operator the statistical information about the “in service” system state (counter and last date).

On the local control panel the following data are shown:



```

IN SVC
-----
COUNTER: XXXXXXXXXX
LAST DATE: mm/dd/yyyy
hh:mm:ss
  
```

Press ESC or OK, to return to the Diagnostic menu.

On the PC, the values are shown as below:



SYSTEM COUNTERS		
	Counter	Last Date
Calibration	0	
Out Service	0	
In Service	0	

3.11.7 STAT FREQ

↓			MAIN
↓			SYSTEM INFO
↓			SYSTEM SET UP
↓			CALIBRATION
↓			COMMAND MODE
↓			FAIL & TRIP SETTING
↓			GENERAL SETTING
↓			SYSTEM DATA
↓			COMMUNICATION
OK			DIAGNOSTIC
	↓		STROKE KM
	↓		IN SVC HOURS
	↓		MIN TEMP.
	↓		MAX TEMP.
	↓		AVER.TEMP.
	↓		PERM. TIME
	↓		dP UP-DOWN
	↓		ERROR STAT
	↓		CALIB STAT
	↓		OUT SVC STAT
	↓		IN SVC STAT
	OK		STAT FREQ
		ESC	To return to menu

This selection allows to modify the storage frequency of the diagnostic data.

On the display, the following message appears:



```

STAT FREQ  ON
          01:00
PRESS OK TO CONFIRM
  
```



INSTRUCTION MANUAL DPS (DIGITAL POSITION SYSTEM) QT series (Software)



From this page, it's possible to change the storage frequency, using the ↑ / ↓ buttons, to confirm the value with the OK key or to cancel the selection pressing the ESC key.
Setting 00:00, the storage frequency is disabled.
It's not possible to change this parameter by remote, on the PC.

3.11.8 EVENT LOG

AVAILABLE ONLY ON PC SW. This function allow to read the history of events.



EVENT LOG

```

04/01/2009 17:21:47 PRM: Part Number (Dev.ID) : 1 -> 1
04/01/2009 15:01:51 PRM: SOV Number : 1 -> 3
04/01/2009 14:59:54 No Errors
04/01/2009 14:59:53 PRM: Trips ON St. : nE nE nE nE -> E nE nE nE
04/01/2009 14:59:51 Trip 1
04/01/2009 14:59:51 PRM: Trip 1 Fail Mode : Off -> SSD1
04/01/2009 13:19:30 PRM: Power Fail Mode : Off -> Off
04/01/2009 12:56:05 PRM: Pos.Exc.Err.Mode : Off -> Off
04/01/2009 12:52:53 No Errors
04/01/2009 12:52:52 PRM: Probe. Fail Mode : SSD1 -> Off
04/01/2009 12:52:14 Probe Error
04/01/2009 12:52:13 System startup
04/01/2009 12:48:59 EEPROMEXT0 Error
04/01/2009 12:48:59 EEPROM Global Reset
04/01/2009 12:48:59 EEPROMEXT Global Reset

```

Start Read

Stop Read

Re-Read All

Search Options
 All
 Only Errors
 Only Info
 Only Params

Max Delta Pressure (bar)

Up

Down

[1.25]

0.00

0.00

It is possible to configure the data that has to be displayed directly from the “Search Options” area. The options are: Only errors: will display only error conditions when present – Only info: will display the data only on a change of info condition – Only Params: will display only the parameters when change - All: will display all the events

Using the button is possible to start stop the reading or re-read all the history.



INSTRUCTION MANUAL DPS (DIGITAL POSITION SYSTEM) QT series (Software)



3.12 ADVANCED

↓			MAIN
↓			SYSTEM INFO
↓			SYSTEM SET UP
↓			CALIBRATION
↓			COMMAND MODE
↓			FAIL & TRIP SETTING
↓			GENERAL SETTING
↓			SYSTEM DATA
↓			COMMUNICATION
↓			DIAGNOSTIC
OK			ADVANCED
	ESC		To return to main menu

This option allows to display the advanced menu data on PC software the advanced data and further configurations are inserted in **STI MENU**.

In order to enter into this menu from the local panel, the advanced level password is required.



PASSWORD: *****

The device is supplied by the manufacturer with the default advanced level password:
[OK ↑ ↓ ↑ OK].

At the end of the login phase, the advanced menu will appear on the screen:



PROBE
MOTOR
SOV
4-20mA
PRESSURE
GENERAL

With the keys ↑ / ↓, it 's possible to shift on the demanded line, and pushing the OK button, it's possible to activate or change the selected option.

On PC software in order to access to **STI MENU** is necessary to log in as "advanced user" (password level 2) inserting the advanced level password that is **23456** by default.

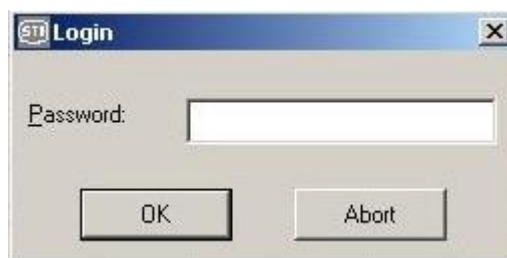

At the end of the login phase, the STI button will appear on the screen:





INSTRUCTION MANUAL DPS (DIGITAL POSITION SYSTEM) QT series (Software)



On the PC, pushing the STI button, the following page is displayed:

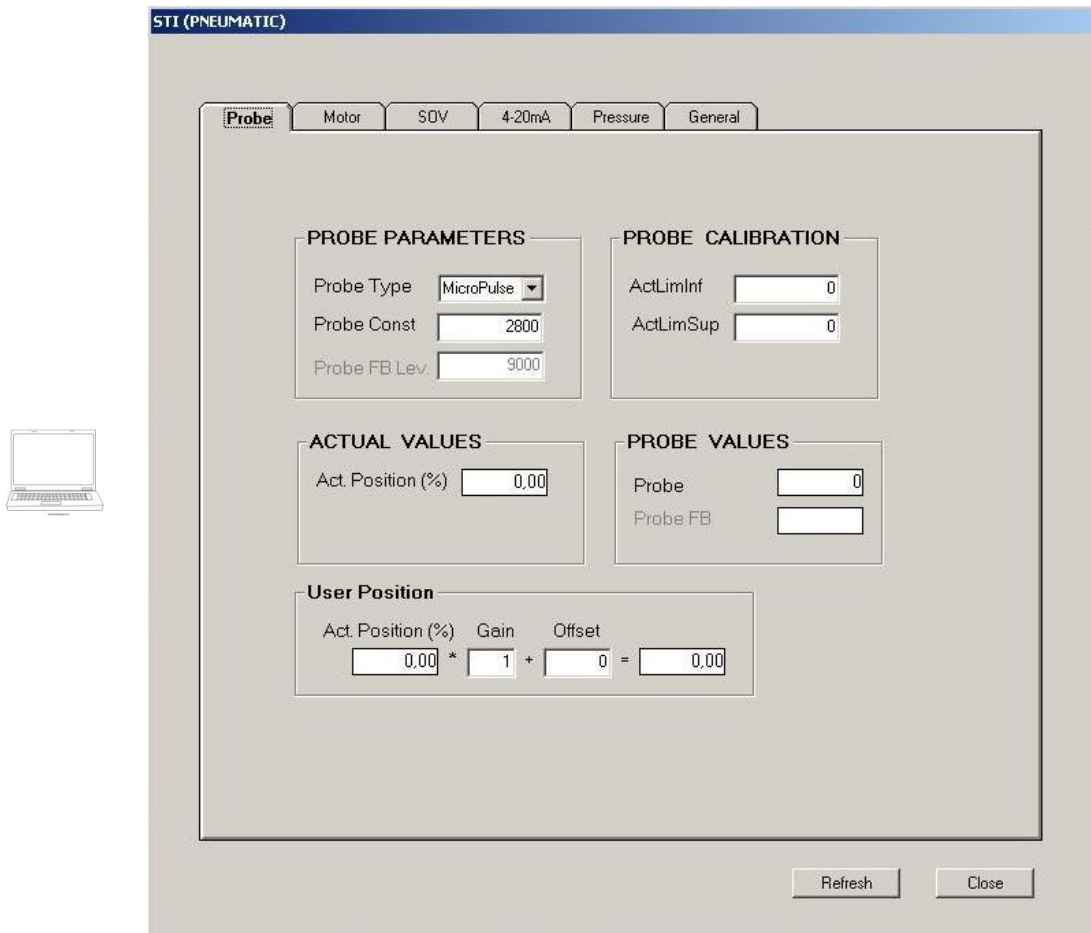

It contains the advanced configuration parameters, the calibration data, some run-time information and the advanced function buttons divided on 6 different tags:

- Probe: probe configuration – probe settings – probe actual reading values
- Motor: Motor and encoder settings – motor manual control
- SOV: Solenoid valve check – SOV manual control
- 4-20mA: Analog input A/D converter reading – Analog outputs D/A converter calibration
- Pressure: Pressure sensors reading – Pressure A/D converter calibration
- General: New functions enable – Erase calibration – Reset device

3.12.1 PROBE

↓			MAIN
↓			SYSTEM INFO
↓			SYSTEM SET UP
↓			CALIBRATION
↓			COMMAND MODE
↓			FAIL & TRIP SETTING
↓			GENERAL SETTING
↓			SYSTEM DATA
↓			COMMUNICATION
↓			DIAGNOSTIC
OK			ADVANCED
	OK		PROBE
		ESC	To return to menu

Selecting PROBE will be displayed the probe configuration page



INSTRUCTION MANUAL DPS (DIGITAL POSITION SYSTEM) QT series (Software)



```

PROBE TYPE      XXXXXX
PROBE CONST     XXXX
PROBE FB LEVEL  XXXX
ACTLIM INF      XXXX
ACTLIM SUP      XXXX
  
```

PROBE TYPE: With this command, it is possible to define the system probe selecting the line with the up / down buttons and scrolling the options by pushing the OK key. The available options are: MICROPULSE, 4-20 mA, LVDT.

PROBE CONST: Allow to set the probe constant in order to have the right conversion between the probe reading value (Pulses) and the real stem movement value (millimetres or inches).

PROBE FB LEVEL: Shows the feedback level of the probe.

ACTLIM INF: Shows the probe reading lower limit found with the calibration.

ACTLIM SUP: Shows the probe reading upper limit found with the calibration.

On PC SW selecting the “Probe” label will be displayed:



Where are shown more information and functions

ACTUAL VALUES: is the position of the actuator expressed in %

PROBE VALUES: are the real time reading values related to probe signal

NEW FUNCTION

Starting from Release 4.01 the **User Position** function is implemented. It allows to customize the Analog feedback (Analog out A and B) using a **GAIN** factor that will be multiplied to the ACT % position and an **OFFSET** factor that will be added to the result between ACT % position multiplied to the Gain.



INSTRUCTION MANUAL DPS (DIGITAL POSITION SYSTEM) QT series (Software)



3.12.2 MOTOR

↓		MAIN
↓		SYSTEM INFO
↓		SYSTEM SET UP
↓		CALIBRATION
↓		COMMAND MODE
↓		FAIL & TRIP SETTING
↓		GENERAL SETTING
↓		SYSTEM DATA
↓		COMMUNICATION
↓		DIAGNOSTIC
OK		ADVANCED
	↓	PROBE
	OK	MOTOR
	ESC	To return to menu

Selecting this option is possible to enter in the motor menu:

```

TH. 0 SPOOL      XXXX
SPOOL LIMIT
STEP MOTOR
MOTOR TEST
STEP 0           XXXX
STEP 0N         XXXX
  
```

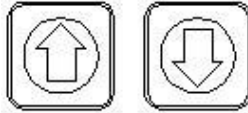

```

STEP0P          XXXX
POSINDEX0       XXXX
POSINDEXORI     XXXX
MOTOR STEPS     XXXX
ALIGN.STEPS     XXXX
ENCODER         XXXX
  
```

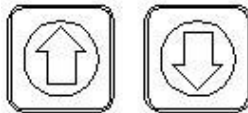

STEP MOTOR

TH. 0 SPOOL: Displays the theoretical 0 position of the spool. This value is related at the mechanical geometry of the spool.

SPOOL LIMIT: selecting this option with OK is possible to set the mechanical minimum and maximum limit.



```

SPOOL MIN LIMIT -XXXX
SPOOL MAX LIMIT  XXXX
  
```

STEP MOTOR: Allows to enter the motor configuration data.



```

SPEED INI      XX
SPEED MAX     XX
ACC. TME      XXX
  
```



INSTRUCTION MANUAL DPS (DIGITAL POSITION SYSTEM) QT series (Software)



Warning: changing the motor configuration may generate errors on the spool and actuator movement or damage the motor and the spool.

MOTOR TEST: When the actuator is **NOT CALIBRATED** allows to test automatically the motor.



HARD LIMIT SEARCH
INDEX SEARCH
START MOTOR

STEP0: Displays the mechanical zero position found during the autocalibration.

STEP0N: Shows the negative point that is possible to reach with no movement on actuator.

STEP0P: Positive point that is possible to reach with no movement on actuator.

POSINDEX0: Display the index 0 position.

POSINDEXORI: Displays the origin index position.

MOTOR STEPS: Counter of motor steps (x 1000).

ALIGN STEPS: Counter of aligned steps (x 1000).

ENCODER: Actual encoder position.

STEP MOTOR: Actual step motor position.

On PC software the motor data are in **MOTOR** tag of **STI MENU**.



The screenshot shows the 'Motor' tab in the STI (PNEUMATIC) software. The interface is divided into several sections:

- CALIBRATION DATA:**
 - Step0: 3800
 - Step0N: 3800
 - Step0P: 3800
 - PosIndex0: 0
 - PosIndexOri: 0
 - Spool Range: 7000
- DIAGNOSTIC:**
 - Motor Steps: 0 x1000
 - Aligned Steps: 0 x1000
 - Max Step Error: 0
 - Last Step Error: 0
 - Spool Range: 0
 - Spool Min: -4000
 - Spool Max: 4000
- MECH. PARAMETERS:**
 - Th. 0 Spool: 3500
 - Spool Min Limit: -3100
 - Spool Max Limit: 3100
- POSITION:**
 - Encoder: 0
 - Step Motor: 0
- SPEED PARAMETERS:**
 - Speed Ini: 50
 - Speed Max: 14
 - Acc. Time: 100
- MANUAL CONTROL:**
 - Do Steps: + - [input field]
 - Enc. Reset [button]
 - Enc. Align [button]

At the bottom of the window are 'Refresh' and 'Close' buttons.

From this page when the system is **NOT CALIBRATED** and **ONLY** from PC software is possible to move manually the step motor. To drive it manually insert the number of steps to be driven in **MANUAL CONTROL**



INSTRUCTION MANUAL DPS (DIGITAL POSITION SYSTEM) QT series (Software)



area and click on + or - button the motor will move according with the direction selected pushing the button. To check if the motor moved check the POSITION area that will shows the motor and encoder position. The values of Encoder and Step Motor HAS to be aligned (max error 100 unit).



In manual control is suggested to insert a low number of steps (100 – 200) and drive the motor only a few times per each direction in order to avoid to reach the mechanical limit with the spool. If it happen driving a step the value of step motor in position area will increase but the encoder will stay in the same position. To fix the phase displacement it is possible to use the buttons ENC RESET and ENC ALIGN. ENC RESET will reset the value of Encoder and Step motor position. ENC ALIGN will set the encoder value as the step motor value.

3.12.3 SOV

↓			MAIN
↓			SYSTEM INFO
↓			SYSTEM SET UP
↓			CALIBRATION
↓			COMMAND MODE
↓			FAIL & TRIP SETTING
↓			GENERAL SETTING
↓			SYSTEM DATA
↓			COMMUNICATION
↓			DIAGNOSTIC
OK			ADVANCED
	↓		PROBE
	↓		MOTOR
	OK		SOV
		ESC	To return to menu

From controller panel is possible to set only the SOV feedback.



SOV FEEDBACK XXXXXX

On PC software is also possible to activate manually the solenoid valves using the command Force EV in manual control.



INSTRUCTION MANUAL DPS (DIGITAL POSITION SYSTEM) QT series (Software)

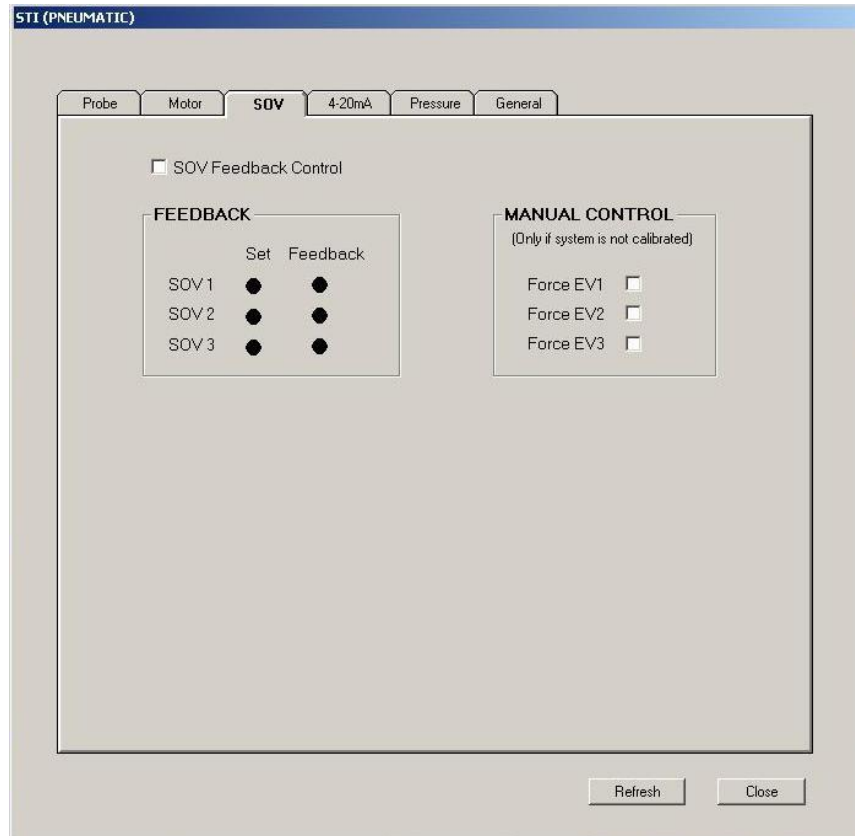

CAUTION: Forcing the solenoid valves may let the valve move unexpectedly. The plant operator has the responsibility to make sure that the process valve, will not cause any damage to property or personnel before issuing the “FORCE EV” command. This includes making sure that personnel and equipment are clear of moving parts of the cylinder and process valve and that the plant process has been made safe by bypassing the process valve.

3.12.4 4-20 mA

↓			MAIN
↓			SYSTEM INFO
↓			SYSTEM SET UP
↓			CALIBRATION
↓			COMMAND MODE
↓			FAIL & TRIP SETTING
↓			GENERAL SETTING
↓			SYSTEM DATA
↓			COMMUNICATION
↓			DIAGNOSTIC
OK			ADVANCED
	↓		PROBE
	↓		MOTOR
	↓		SOV
OK			4-20mA
		ESC	To return to menu

With this command, it is possible to see the 4-20 mA values.



INSTRUCTION MANUAL DPS (DIGITAL POSITION SYSTEM) QT series (Software)



```

INP CONV4mA   XXXXX
INP CONV20mA  XXXXX
OUT1 CONV4mA  XXXXX
OUT1 CONV20mA XXXXX
OUT2 CONV4mA  XXXXX
OUT2 CONV20mA XXXXX
  
```

From remote control software is possible to read the values of input analog to digital converter and calibrate the analog outputs.

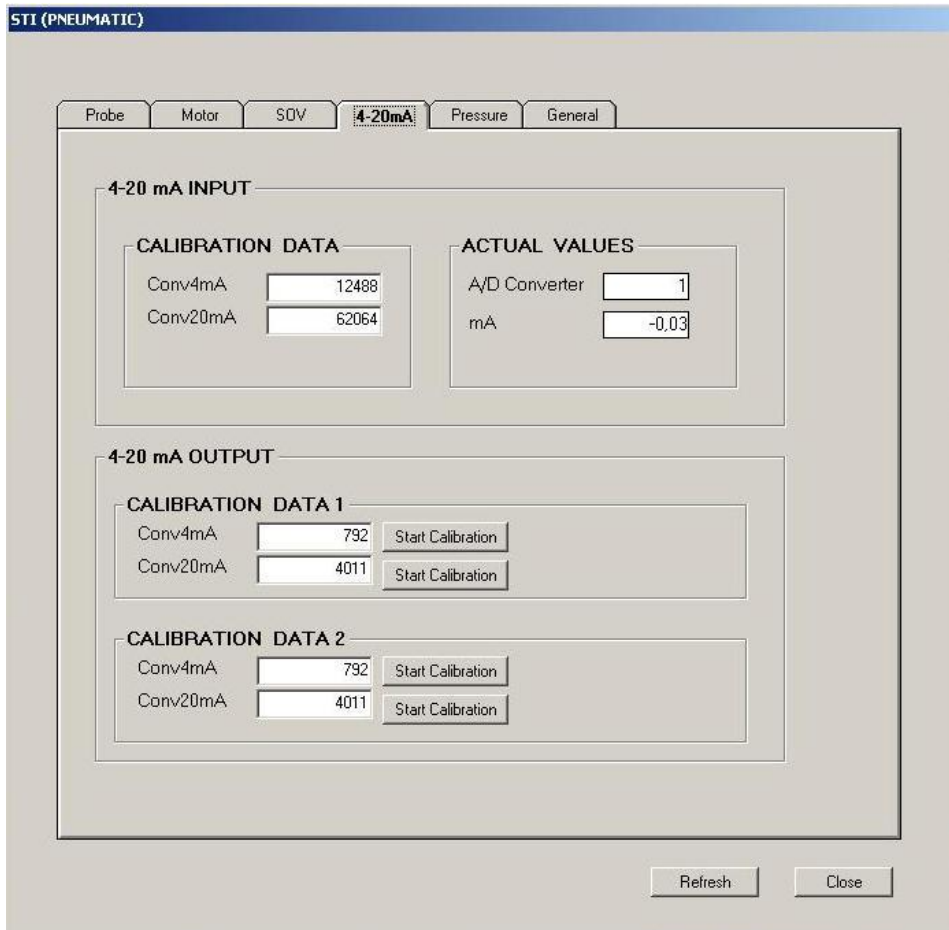

To calibrate the outputs is necessary to connect the measuring instrument to the related output and press the start calibration button, read the output value on the instrument and modify the output clicking on - or + buttons. Once found the right value push Confirm. Cancel to abort the calibration.

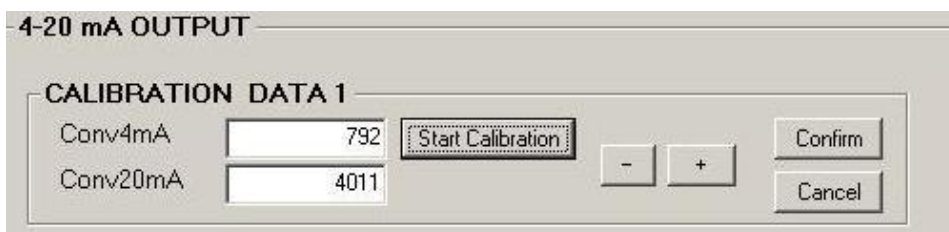



INSTRUCTION MANUAL DPS (DIGITAL POSITION SYSTEM) QT series (Software)



3.12.5 PRESSURE

↓		MAIN
↓		SYSTEM INFO
↓		SYSTEM SET UP
↓		CALIBRATION
↓		COMMAND MODE
↓		FAIL & TRIP SETTING
↓		GENERAL SETTING
↓		SYSTEM DATA
↓		COMMUNICATION
↓		DIAGNOSTIC
OK		ADVANCED
	↓	PROBE
	↓	MOTOR
	↓	SOV
	↓	4-20mA
OK		PRESSURE
	ESC	To return to menu

PI – SRC P1 XXXXX
 PI – SRC P2 XXXXX
 PI – SRC P3 XXXXX
 PI – TRG P1 XXXXX
 PI – TRG P2 XXXXX
 PI – TRG P3 XXXXX

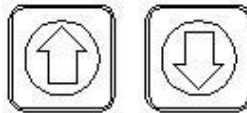

PA – SRC P1 XXXXX
 PA – SRC P2 XXXXX
 PA – SRC P3 XXXXX
 PA – TRG P1 XXXXX
 PA – TRG P2 XXXXX
 PA – TRG P3 XXXXX

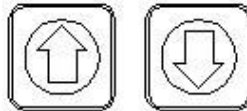

PB – SRC P1 XXXXX
 PB – SRC P2 XXXXX
 PB – SRC P3 XXXXX
 PB – TRG P1 XXXXX
 PB – TRG P2 XXXXX
 PB – TRG P3 XXXXX

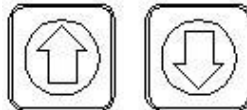

PI CALIB
 PA CALIB
 PBCALIB



- **PI – Src P1:** it's the lower value of PI-SUPPLY expressed in A/D converter points used to calibrate this pressure transducer
- **PI – Src P2:** it's the middle value of PI-SUPPLY expressed in A/D converter points used to calibrate this pressure transducer
- **PI – Src P3:** it's the higher value of PI-SUPPLY expressed in A/D converter points used to calibrate this pressure transducer
- **PI – Trg P1:** it's the lower value of PI-SUPPLY expressed in measurement units (bar, Psi) used to calibrate this pressure transducer



INSTRUCTION MANUAL DPS (DIGITAL POSITION SYSTEM) QT series (Software)



- **PI – Trg P2:** it's the middle value of PI-SUPPLY expressed in measurement units (bar, Psi) used to calibrate this pressure transducer
- **PI – Trg P3:** it's the higher value of PI-SUPPLY expressed in measurement units (bar, Psi) used to calibrate this pressure transducer
- **PA – Src P1:** it's the lower value of PA-SUPPLY expressed in A/D converter points used to calibrate this pressure transducer
- **PA – Src P2:** it's the middle value of PA-SUPPLY expressed in A/D converter points used to calibrate this pressure transducer
- **PA – Src P3:** it's the higher value of PA-SUPPLY expressed in A/D converter points used to calibrate this pressure transducer
- **PA – Trg P1:** it's the lower value of PA-SUPPLY expressed in measurement units (bar, Psi) used to calibrate this pressure transducer
- **PA – Trg P2:** it's the middle value of PA-SUPPLY expressed in measurement units (bar, Psi) used to calibrate this pressure transducer
- **PA – Trg P3:** it's the higher value of PA-SUPPLY expressed in measurement units (bar, Psi) used to calibrate this pressure transducer
- **PB – Src P1:** it's the lower value of PB-SUPPLY expressed in A/D converter points used to calibrate this pressure transducer
- **PB – Src P2:** it's the middle value of PB-SUPPLY expressed in A/D converter points used to calibrate this pressure transducer
- **PB – Src P3:** it's the higher value of PB-SUPPLY expressed in A/D converter points used to calibrate this pressure transducer
- **PB – Trg P1:** it's the lower value of PB-SUPPLY expressed in measurement units (bar, Psi) used to calibrate this pressure transducer
- **PB – Trg P2:** it's the middle value of PB-SUPPLY expressed in measurement units (bar, Psi) used to calibrate this pressure transducer
- **PB – Trg P3:** it's the higher value of PB-SUPPLY expressed in measurement units (bar, Psi) used to calibrate this pressure transducer



INSTRUCTION MANUAL DPS (DIGITAL POSITION SYSTEM) QT series (Software)



On remote control software the related page is in STI expert menu Pressure tag.

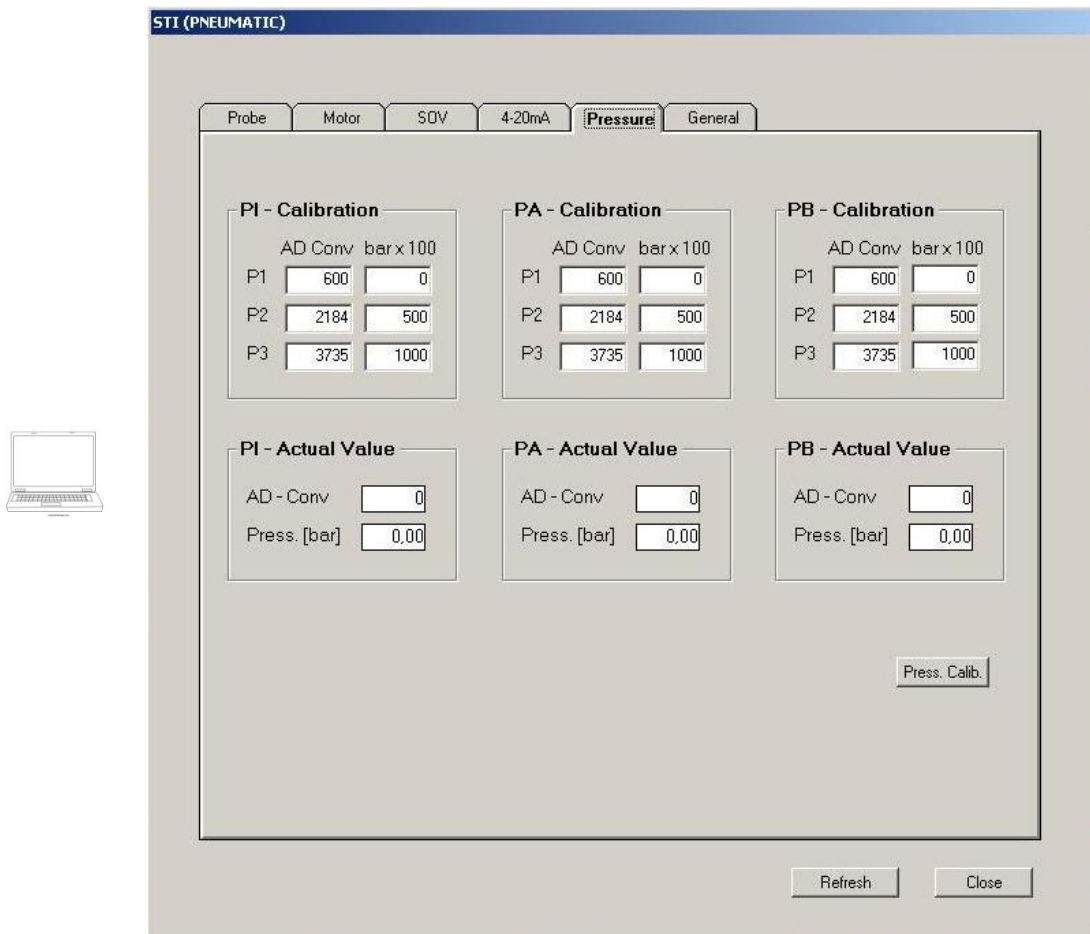

On display selecting the PI CALIB function, the following menu appears on the display:



PI-P1 CALIB.
PI-P2 CALIB.
PI-P3 CALIB.

With this command, selecting the required point, it's possible to calibrate the SUPPLY-PI pressure signal.



PI-P1
0.00 Bar
PRESS OK TO CONFIRM

The second line value can be changed by pressing the key \uparrow / \downarrow in a range between 0÷150 Psi or 0÷10 bar and subsequently confirmed with OK. Press ESC to return to the previous menu.

This function is available on PC software from the STI menu, pushing the Calib. Button.

To calibrate the pressure signal, select the pressure transducer type (PI/PA/PB), input the value in the required empty cell and press the corresponding Calib. button.



INSTRUCTION MANUAL DPS (DIGITAL POSITION SYSTEM) QT series (Software)



Selecting PA-CALIB function, the following menu appears on the display:



PA-P1 CALIB.
PA-P2 CALIB.
PA-P3 CALIB.

With this command, selecting the required point, it's possible to calibrate the OUT1-PA pressure signal.



PA-P1
0.00 Bar
PRESS OK TO CONFIRM

The second line value can be changed by pressing the key \uparrow / \downarrow in a range between 0÷150 Psi or 0÷10 bar and subsequently confirmed with OK. Press ESC to return to the previous menu.

This function is available on PC software from the STI menu, pushing the Calib. Button.

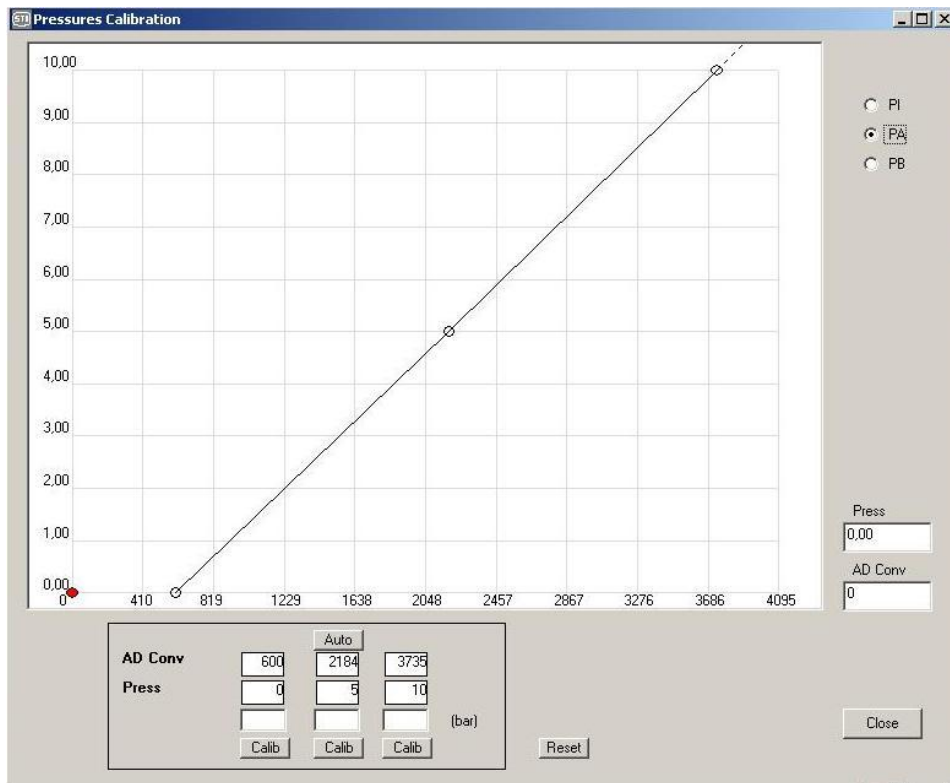

To calibrate the pressure signal, select the pressure transducer type (PI/PA/PB), input the value in the required empty cell and press the corresponding Calib. button.

This function is available on PC software from the STI menu, pushing the Press. Calib. Button.

Selecting this function, the following menu appears on the display:



PB-P1 CALIB.
PB-P2 CALIB.
PB-P3 CALIB.

With this command, selecting the required point, it's possible to calibrate the OUT1-PA pressure signal.



INSTRUCTION MANUAL DPS (DIGITAL POSITION SYSTEM) QT series (Software)



PB-P1
0.00 Bar
PRESS OK TO CONFIRM

The second line value can be changed by pressing the key \uparrow / \downarrow in a range between 0÷150 Psi or 0÷10 bar and subsequently confirmed with OK. Press ESC to return to the previous menu.

This function is available on PC software from the STI menu, pushing the Calib. Button.

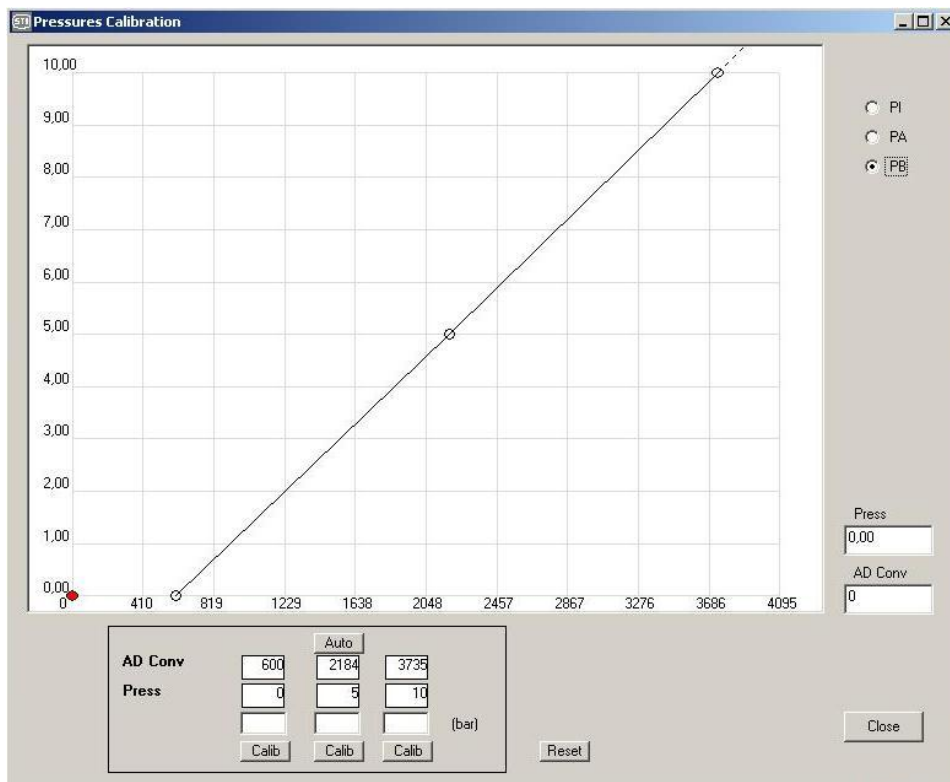

To calibrate the pressure signal, select the pressure transducer type (PI/PA/PB), input the value in the required empty cell and press the corresponding Calib. button.

3.12.6 GENERAL

↓			MAIN
↓			SYSTEM INFO
↓			SYSTEM SET UP
↓			CALIBRATION
↓			COMMAND MODE
↓			FAIL & TRIP SETTING
↓			GENERAL SETTING
↓			SYSTEM DATA
↓			COMMUNICATION
↓			DIAGNOSTIC
OK			ADVANCED
	↓		PROBE
	↓		MOTOR
	↓		SOV
	↓		4-20mA
	↓		PRESSURE
OK			GENERAL
		ESC	To return to menu

With this command, it is possible to enter the General setting menu:

```

PART NUMBER      XX
PASSWORD
CHAM MODE        XXXXX
FULL SPEED       XXXXX
ON MODE          XXXXX
P1-P3
  
```

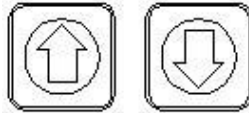

```

SET AS DEFAULT
ERASE CALIB
RESET STAT&LOG
STAT DEBUG
HART DEBUG
  
```

On PC software the function are available in General tag in STI menu page.

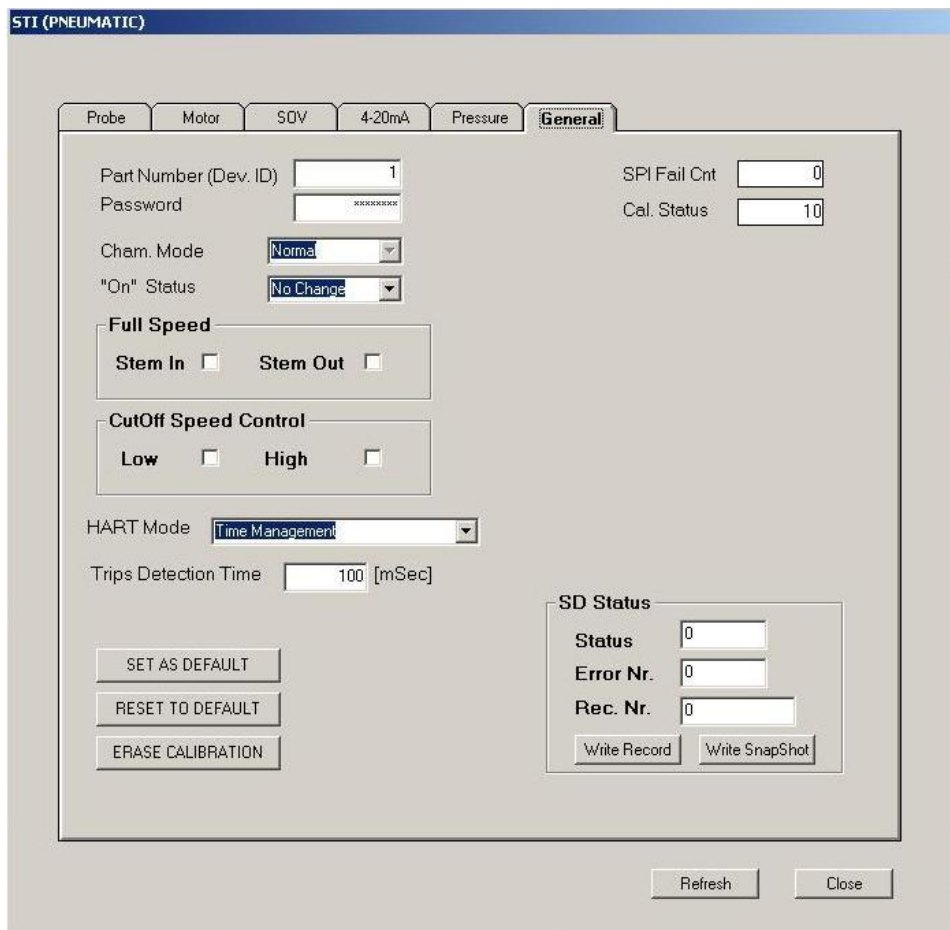

3.12.6.1 PART NUMBER

With this command, it is possible to modify the QuickTrak III part number, in a range of 1-32767. In the HART Protocol this number corresponds to the Device ID.

The following page is displayed:



PART NUMBER
1
 PRESS OK TO CONFIRM

In this page with the 4 keys enabled, it's possible:

- to change the proposed value increasing it with the STEM \square and decreasing it with the STEM \square ;
- to cancel the possible changes and return to the Advanced submenu with the ESC key;
- to confirm the inserted value by pressing OK.

To change the parameter from PC software from the STI menu double click on parameter and type the new value.

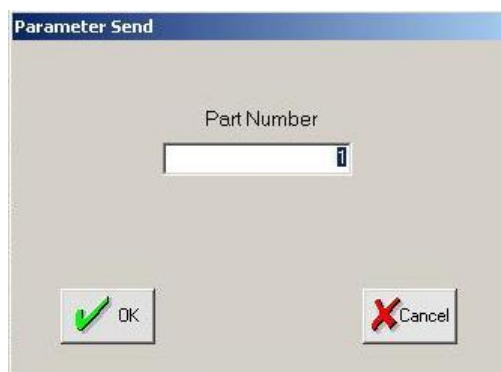

To set the value, double click on the corresponding cell, input the value and press "OK" to confirm it or "Cancel" to exit from the input window.

3.12.6.2 PASSWORD

With this selection, it's possible to change the advanced level password.

The following page is displayed:



PASSWORD: _ _ _ _ _
 CONFIRM: _ _ _ _ _

A sequence of 5 push buttons is required to define this password, used to enter the advanced menu from the local panel (the device is supplied by the manufacturer with the default advanced password [OK \uparrow \downarrow \uparrow OK]).

This function is available on PC software from the STI menu.





INSTRUCTION MANUAL DPS (DIGITAL POSITION SYSTEM) QT series (Software)



To set the value, double click on the corresponding cell, input the value and press “SEND” to confirm it or “ABORT” to exit from the input window.

3.12.6.3 CHAMBER MODE

This function is related at the piping of the actuator. It is auto defined during the Calibration

3.12.6.4 FULL SPEED

NEW FUNCTION

Starting from DSP release 4.01 is available the FULL SPEED mode. This function has been inserted in order to increase the performance of the actuator on full stroke movement. When the actuator position is on a limit (0% or 100%) and a full stroke is requested the positioner full pressurize the related chamber bypassing all the tuning parameter.

Different settings are available

- Not enabled
- Stem in only
- Stem out only
- Both direction

On PC software is possible to set the function clicking the needed function

3.12.6.5 ON MODE

NEW FUNCTION

Starting from DSP release 4.01 is available the ON MODE function.

This option allows to select the status on power up. Is possible to choose between three parameters:

- NO CHANGE
- OUT OF SERVICE
- IN SERVICE

NO CHANGE: on power up the last status before the switch off is maintained

OUT OF SERVICE: on power up the service status will be set in OUT OF SERVICE mode

SERVICE: on power up the service status will be set in IN SERVICE mode

On PC software just select the needed function

3.12.6.6 P1-P3

PARAMETER NOT USED.

3.12.6.7 SET AS DEFAULT

All the actual parameters set on positioner will be saved in internal memory as default.

3.12.6.8 ERASE CALIBRATION

With this function is possible to erase the calibration data.

3.12.6.9 RESET STAT&LOG

Allows to erase the statistics and event log file.

3.12.6.10 STAT DEBUG

Reserved debug page containing information about the statistical calculation and the recording time in External EEPROM.

3.12.6.11 HART DEBUG

Reserved debug page containing information about the input/output HART frames.



INSTRUCTION MANUAL DPS (DIGITAL POSITION SYSTEM) QT series (Software)



3.12.7 REMOTE CONTROL SW >>> STI PAGE >>> GENERAL TAG

On GENERAL tag of STI PAGE are available NEW OPTIONS included since Version 4.01

STI (PNEUMATIC)

Probe Motor SOV 4-20mA Pressure **General**

Part Number (Dev. ID) SPI Fail Cnt
 Password Cal. Status
 Cham. Mode
 "On" Status

Full Speed
 Stem In Stem Out

CutOff Speed Control
 Low High

HART Mode
 Trips Detection Time [mSec]

SET AS DEFAULT
 RESET TO DEFAULT
 ERASE CALIBRATION

SD Status
 Status
 Error Nr.
 Rec. Nr.
 Write Record Write SnapShot

Refresh Close

3.12.7.1 ON STATUS

NEW FUNCTION



"On" Status

This option allows to select the status on power up. Is possible to choose between three parameters:

- NO CHANGE
- OUT OF SERVICE
- IN SERVICE

NO CHANGE: on power up the last status before the switch off is maintained
 OUT OF SERVICE: on power up the service status will be set in OUT OF SERVICE mode

SERVICE: on power up the service status will be set in IN SERVICE mode



INSTRUCTION MANUAL DPS (DIGITAL POSITION SYSTEM) QT series (Software)



3.12.7.2 FULL SPEED

NEW FUNCTION



This function has been inserted in order to increase the performance of the actuator on full stroke movement. When the actuator position is on a limit (0% or 100%) and a full stroke is requested the positioner full pressurize the related chamber bypassing all the tuning parameter. To enable the function flag the related direction.

3.12.7.3 CUT OFF SPEED CONTROL

NEW FUNCTION



This function works linked with the STROKE time function (SEE RELATED CHAPTER). When selected one or both of these options (Cut off speed control on Low position Cut Off or/and High position Cut OFF), if a Cut off position is selected and a stroke time is set the actuator will move according to the stroke time. This function is used to maintain the cut off function and the linearity request for the stoking time

3.12.7.4 TRIPS DETECTION TIME

NEW FUNCTION

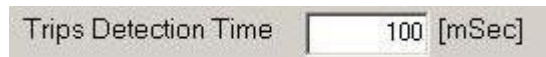

This function allows to set a delay time on the detection of the error condition due to a trip signal



INSTRUCTION MANUAL DPS (DIGITAL POSITION SYSTEM) QT series (Software)



3.13 REMOTE CONTROL SW >>> TOOLBAR OPTIONS



From software toolbar is possible to select different functions contained in menus:

- File
- Device
- Password
- Data recording

3.13.1 FILE MENU

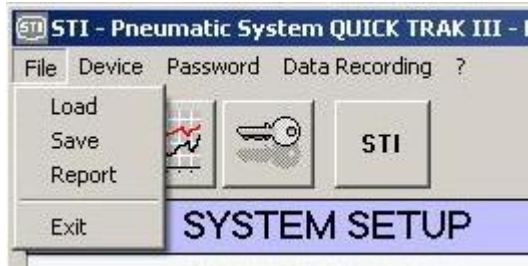

The available functions are:

- **Load:** allows to load a saved parameter file

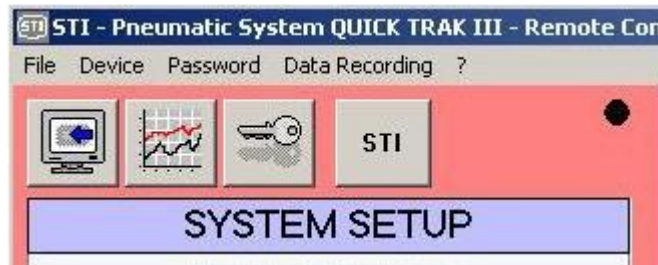

Once load a file the background of the program window changes color

- **Save:** saves the on-line parameters. The extension of the file is .qtp
- **Report:** creates a text file with all the positioner parameters
- **Exit:** close the program

3.13.2 DEVICE MENU

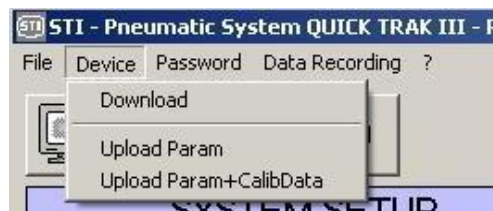

In this menu the available options are

- **Download:** read the parameters from the positioner
- **Upload Param:** this function is available starting from password level 1 and it allows to send from the PC to the positioner the configuration data loaded from a file (backup file)



INSTRUCTION MANUAL DPS (DIGITAL POSITION SYSTEM) QT series (Software)



- **Upload Param + CalibData:** This function is available with password level 2 and it allows to send from the PC to the positioner the configuration data and the calibration data loaded from a file. *NOTE: it is ever suggested upload ONLY the parameters and perform an auto-calibration*

3.13.3 PASSWORD MENU



- **Login:** Used to login in to the sw. Password level1: 12345 Password level2: 23456
- **Change:** allows to change the password

3.13.4 DATA RECORDING MENU

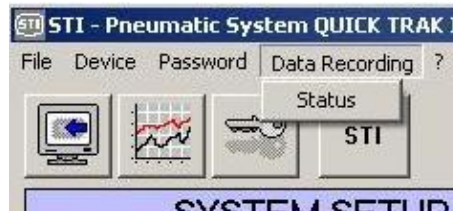

Allows to save on pc a log file.

3.13.5 INFO MENU



Selecting info menu is possible to display the release of the positioner.

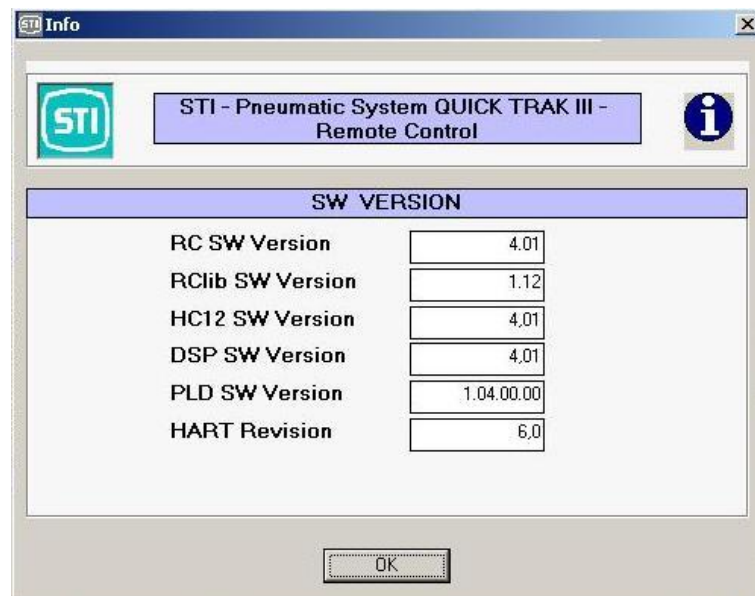



INSTRUCTION MANUAL DPS (DIGITAL POSITION SYSTEM) QT series (Software)



4 GRAPH

This feature allows user to record set point and position signal waveforms for 10 seconds. Moreover, it comes with some tools to analyze the acquired waveforms. This feature is available just on the “Remotectrl” program. To enable this feature, user must put the system into MANUAL mode. Open the Graph window clicking the GRAPH button on the remote control panel.



Below a detailed description of the available GRAPH tools:

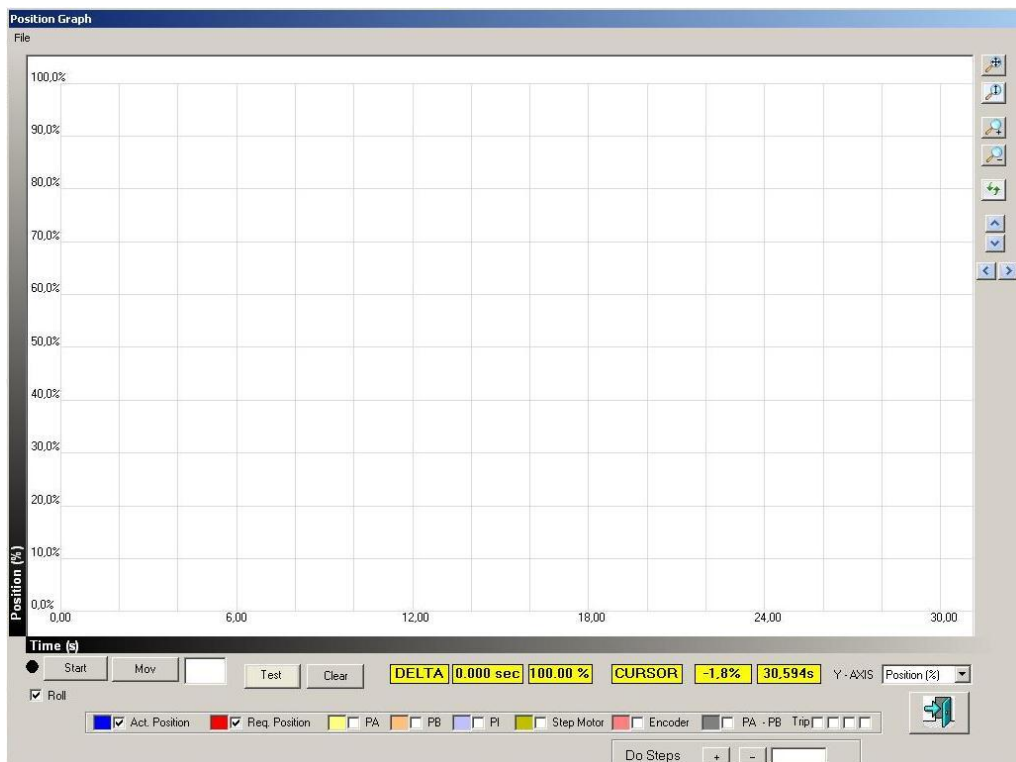

The GRAPH tool allows to check the performances of all actuator parameters.

Selecting the options in the lower area of the GRAPH is possible to select the options that has to be shown.



The available options are:

Act. Position: Is the actual position

Req. Position: Is the request position

PA: Is pressure in chamber A

PB: Is pressure in chamber B

PI: Is Supply pressure

Step Motor: It shows the steps of the motor

Encoder: Is the encoder position

PA - PB: Is the Delta (differential) pressure between chamber A and chamber B

Trip: Shows Trips 1,2,3,4 (selecting from left to right)

Once selected the graph options is necessary to press the “Start” button to start the monitoring of the parameters. The default scanning time is 30 seconds but using the “Roll” option (located under start button) the scanning will not stop until the closing of graph page or removing the Roll flag.



In order to deep analyze the performances of the actuator are available some functions to check easily the parameters.

Cursor position: Moving the cross cursor on the graph area is possible to read the cursor position (Y,X) in the yellow area named “CURSOR”.

Delta measuring: Is possible to measure the distance between two points on the graph. Move the cross cursor on the first point, push and hold the right mouse button, move the cursor on the second point and release the right button. In DELTA yellow area will be possible to read the last sampling. While holding the button a line appears to identify the measuring delta.

Y – AXIS configuration: It allows to select the measuring unit for Y axe. It is possible to select between “Position (%)”, “pressure (bar)” or “Motor steps”. The Y axis is auto rescaled according to the measuring unit.

Mov button (manual movement): When the service status is in MANUAL mode is possible to move the actuator directly from the graph. Insert the desired position in the MOV area (near the button) and click on MOV button.

Test button: Function available ONLY in MANUAL mode. With this function is possible to let the actuator moving automatically to 2 defined position with a pre-set delay time.

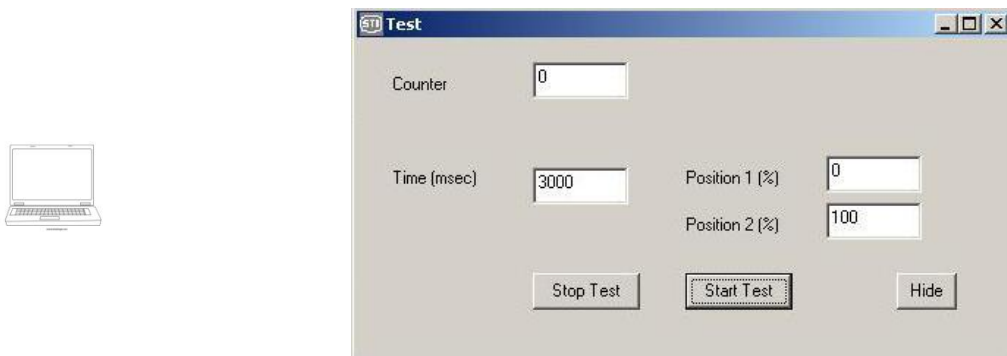

Clear button: allows to clean the screen.

Do steps: ONLY WHEN NOT CALIBRATED. Is possible to manual drive the motor directly from the graph like in STI expert menu. Insert the number of steps to do and press Do Steps. Remember to insert a low number of step to avoid spool crashes. SEE related chapter (STI menu -> MOTOR tag) for more information.

Zoom function: selecting an area on the graph is possible to zoom in. To do it move the cross cursor on the left- top corner of the desired area to zoom in, push and hold the left button, move the mouse to the right-down corner of the area. While holding the button a box appears to identify the zoom area. On the left-top corner of the graph area are available further zoom tools

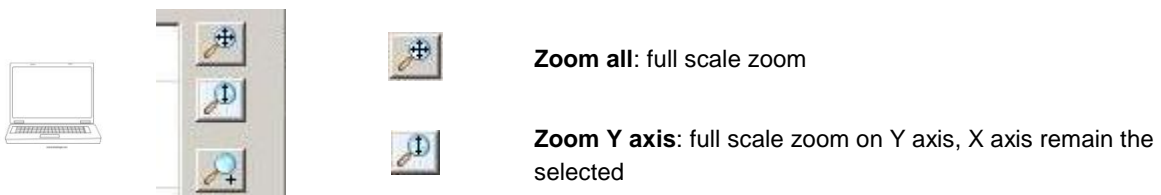



INSTRUCTION MANUAL DPS (DIGITAL POSITION SYSTEM) QT series (Software)



Zoom in – Zoom out



Refresh graph data

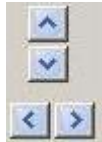

Scroll buttons: Allow to scroll the graph in each direction, is also possible to use the arrow keys on keyboard

In graph page it is possible also to use the file function

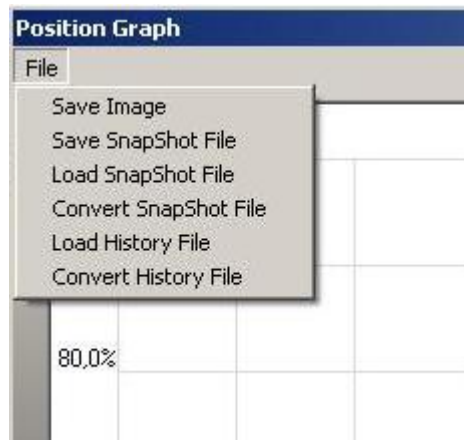

The options available are:

- **Save Image:** saves the actual measuring screen as bitmap image
- **Save Snapshot File:** saves the actual measuring screen as binary file (.bin extension). Into the file are saved all the actuator parameters.
- **Load Snapshot File:** load a stored binary file. Once loaded the file is possible to full analyze the graph (show or hide parameters, zoom, measure) like in on-line graph
- **Convert Snapshot File:** convert the snapshot binary file in a .csv file (excel extension)
- **Load History File:** Load an history file stored in the SD CARD (SEE RELATED CHAPTER) . Opening the file is possible to select the portion of the historical file to be displayed
- **Convert History File:** Convert the history file stored in SD CARD in a .csv file.



INSTRUCTION MANUAL DPS (DIGITAL POSITION SYSTEM) QT series (Software)



5 TROUBLE SHOOTING

Problem description	Cause	Solution
The controller doesn't switch on	<ul style="list-style-type: none"> The power is not connected The power supply voltage is out of the admissible range (+/-10%) The main power switch inside the controller is OFF The fuses are blown Some wiring is not properly done either inside The controller or in the step motor enclosure There is a short circuit on some of the devices connected to the controller 	<ul style="list-style-type: none"> Connect the power Check the power supply voltage value with a multimeter Switch on the main power switch Replace the fuses Check the wiring using the electrical diagram and that the connector to step motor, encoder and pressure transducers is properly plugged. Disconnect all the terminal boards connected to these device and check whether the controller switches on.
Probe error E10	<ul style="list-style-type: none"> Some wiring is not properly done The software selection in STI menu of the used probe is not correct The probe has been calibrated with a shorter stroke process valve The probe is damaged 	<ul style="list-style-type: none"> Check the wiring Check that the software setting corresponds to the used probe Erase the previous calibration and perform a new calibration Replace the probe
Red light flashing on motor-driver electronic board	<ul style="list-style-type: none"> The step motor connector is not properly plugged The wiring is not properly done There is an excessive friction on the spool valve driven by the step motor 	<ul style="list-style-type: none"> Check the connector plug Check the wiring Check that the spool valve can slide smoothly and in STI menu the difference between step motor and encoder steps is not too big
A change in the valve position set point doesn't affect the actuator's position	<ul style="list-style-type: none"> The air supply pressure value is too low The spool valve is sticking The parameters configuration is not correct Actuator and/or jammed valve Signal wires are not properly connected Circuit boards are defective Calibration and tuning have not been carried out Device is in "manual" or "out of service" mode Device is in fail safe status 	<ul style="list-style-type: none"> Check the air supply pressure value Check that the spool valve can slide smoothly and in STI menu the difference between step motor and encoder steps is not too big Check gain and dead band values Check that the actuator can move in a continuous way and not in steps Check signal wires Replace circuit boards Perform a calibration and make the proper tuning Set the system in "in service" mode Check whether the solenoid valve making the fail safe mode is energized
Overshooting or positioning too slow	<ul style="list-style-type: none"> Incorrect tuning in terms of dead band and gain The spool valve is sticking Too small air tubing or dirty air filter Leakages in air tubing and manifold connections Process valve is sticking 	<ul style="list-style-type: none"> Change the dead band and gain values Check that the spool valve can slide smoothly and in STI menu the difference between step motor and encoder steps is not too big Check air tubing size with the factory and inspect air filter Check leakages in air tubing and manifold connections Check process valve
E05	Pressure fail	<ul style="list-style-type: none"> Check air supply line Check that the air filter regulator is



INSTRUCTION MANUAL DPS (DIGITAL POSITION SYSTEM) QT series (Software)



		properly set
E06	Low signal fail limit	<ul style="list-style-type: none">• Check that the wiring to air supply pressure transducer• Check that the signal wires are properly connected to the terminal board• Check with a multimeter the value of the signal• Check that the internal flat cables between the two terminal boards are properly connected
E07	High signal fail limit	<ul style="list-style-type: none">• Check that the signal wires are properly connected to the terminal board• Check with a multimeter the value of the signal• Check that the internal flat cables between the two terminal boards are properly connected
E08	Position excess error	See point 4. of this table
E09	Position excess warning	See point 4. of this table
E11	Low power fail	<ul style="list-style-type: none">• Check that the power wires are properly connected to the terminal board• Check with a multimeter the value of the power supply• Check that the fuses are not blown
E12	Hard limits error	<ul style="list-style-type: none">• Check the probe is working properly• Check that the air supply value is not too low
E13	DSP timeout	Replace the display electronic board
E14	Watch dog error	Replace the display electronic board
E15	High power fail	<ul style="list-style-type: none">• Check that the power wires are properly connected to the terminal board• Check with a multimeter the value of the power supply
E16	Error on solenoid valve SOV1	<ul style="list-style-type: none">• Check that the solenoid valve's coil is not burnt• Check the wiring between the solenoid valve and the controller if the solenoid valve is supposed to be energized check that the yellow light on the side of the SOV1 connector is ON.
E17	Error on solenoid valve SOV2	<ul style="list-style-type: none">• Check that the solenoid valve's coil is not burnt• Check the wiring between the solenoid valve and the controller if the solenoid valve is supposed to be energized check that the yellow light on the side of the SOV2 connector is ON.



INSTRUCTION MANUAL DPS (DIGITAL POSITION SYSTEM) QT series (Software)



E18	Error on solenoid valve SOV3	<ul style="list-style-type: none">• Check that the solenoid valve's coil is not burnt• Check the wiring between the solenoid valve and the controller• If the solenoid valve is supposed to be energized check that the yellow light on the side of the SOV3 connector is ON.
E19	DSP restart	<ul style="list-style-type: none">• Restart again the controller and check whether the error is cleared• Replace the display electronic board
E20	Calibration erased	<ul style="list-style-type: none">• This is a warning message used to inform that a calibration parameters reset has been performed by the operator
E21	EEProm Error 0	<ul style="list-style-type: none">• If the controller is locked try to restart. If the problem remains change the display electronic board
E22	EEProm Error 1	<ul style="list-style-type: none">• If the controller is locked try to restart. If the problem remains change the display electronic board
E23	HC12 Restart	<ul style="list-style-type: none">• Restart again the controller and check whether the error is cleared• Check the power supply cable of display board• Replace the display electronic board
E24	EEProm Ext Error 0	<ul style="list-style-type: none">• If the controller is locked try to restart. If the problem remains change the display electronic board
E 25	EEProm Ext Error 1	<ul style="list-style-type: none">• If the controller is locked try to restart. If the problem remains change the display electronic board
E26	Probe Out of Range	<ul style="list-style-type: none">• Check the stroke length and perform a new calibration
E31	Calibration aborted	<ul style="list-style-type: none">• During the calibration something aborted the process. Fix the problem and perform a new calibration
E32	Zero spool error	<ul style="list-style-type: none">• Check if the spool is free to move on all length
E33	Zero spool searching	<ul style="list-style-type: none">• Warning message. Second try to find the zero spool during start-up
E34	Spool limit Error	<ul style="list-style-type: none">• Check if the spool is free to move on all length
E35	Friction warning	<ul style="list-style-type: none">• Warning message related to the spool movement
E36	Encoder Error	<ul style="list-style-type: none">• Check if the motor move• Check if the encoder is correctly fixed on the motor• Check the motor and encoder wirings
E37	Friction Error	<ul style="list-style-type: none">• Check if the motor move• Check if the spool can move free on all length• Check if the encoder is correctly fixed on the motor



INSTRUCTION MANUAL DPS (DIGITAL POSITION SYSTEM) QT series (Software)



		<ul style="list-style-type: none">• Check the motor and encoder wirings• Check the motor steps and encoder signal
E38	Encoder Index Error	<ul style="list-style-type: none">• Check if the spool is free to move. Perform a new calibration
E39	Encoder Index2 Error	<ul style="list-style-type: none">• Check if the spool is free to move. Perform a new calibration
E41	Wait ack	<ul style="list-style-type: none">• Waiting for acknowledge after an error condition with end mode set to "Wait ack"
E42	External Solenoid	<ul style="list-style-type: none">• A trip signal is detected on an input configured as "External solenoid"
E43	System Version	<ul style="list-style-type: none">• Check the DSP and HC12 version• Update the fw version

Information in this manual is protected by copyright. All rights are reserved. No part of this manual and relevant mentioned and/or enclosed documentation may be reproduced without written authorization by **STI S.r.l.**

STI S.r.l. is not responsible for possible damage to people, equipment or data which might arise from incorrect use of the product to which the manual is referred.

Information in this document may be modified at any time without notice.



INSTRUCTION MANUAL DPS (DIGITAL POSITION SYSTEM) QT series (motor)



INDEX

1	General prescription	1
1.1	Manufacturer's identification data	1
1.2	General safety instructions	2
1.2.1	Installation	2
1.2.2	Maintenance	3
2	General features	3
3	Mounting procedure	4
4	Maintenance operation	4

1 GENERAL PRESCRIPTIONS



It is strongly recommended that this entire manual be read before attempting to install and operate the system.

1.1 MANUFACTURER'S IDENTIFICATION DATA



Every explosion proof step-motor enclosure mod. DPS is provided with a name plate with its serial number. The year of manufacturing is indicated by the first two numbers of the serial number.

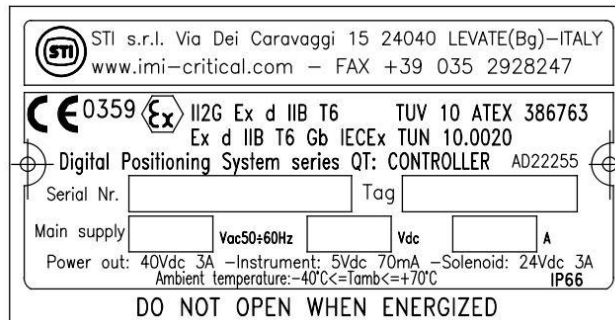

fig. 1 - Sample of equipment label

Manufacturing year is indicated by the two first digit number of the serial number.



Do not remove it and/or replace with other name plates.

The step-motor enclosure mod. DPS, in its explosion proof version, is designed to operate in potentially explosive atmosphere ATEX/IECEx classified as:



**II 2 G Ex d IIC Tx
Ex d IIC Tx Gb**

Equipment group II surface industry, category 2 for use in zone 1 with explosive atmospheres caused by gases, vapours or mists and in conformity to types of protection standardized EN60079-0 and IEC60079-0 with flameproof enclosure EN60079-1 and IEC60079-1 for hydrogen and acetylene (temperature class maximum 85°C).

Range of the permissible ambient temperature are:

- 40° ÷ 50°C for T6
- 40° ÷ 70°C for T5

1.2 GENERAL SAFETY INSTRUCTIONS



The non-observation of the following safety instruction and of the instruction manuals brings with it danger of explosions with serious injury or operator death.

1.2.1 Installation



- Must be done by qualified person trained to operate into potentially explosive atmosphere.
- An external ground connection is mandatory, the section of the conductor must be chosen in accordance to EN60079-0 and IEC60079-0 (a M5 screw is available for the connection).



INSTRUCTION MANUAL DPS (DIGITAL POSITION SYSTEM) QT series (motor)

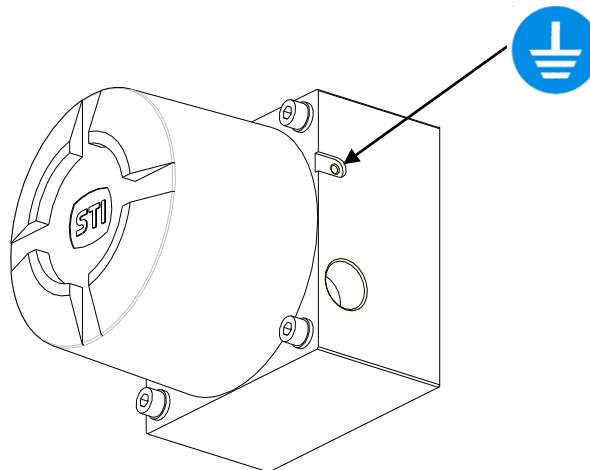

fig. 2 - External ground connection

- The electrical and pneumatic connections must be done according to the diagram and label.
- The supply circuit must be protected in case of current exceeding the limit fixed.
- The equipment must be provided with cable entries and filler plugs certified according to the directive 94/9/EC, EN60079-0, IEC60079-0, EN60079-1 and IEC60079-1 for category 2G.
- The internal ground connection is mandatory, the section of the conductor must be chosen in accordance to EN60079-0 and IEC60079-0 (a M5 screw is available for the connection).

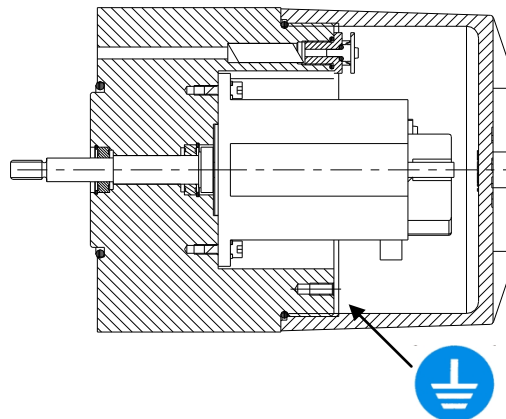

fig. 3 - Internal ground connection

- The actuator must be installed and used according to the project design specification.
- The fluid must be chemically compatible with the used gaskets and lubricant.
- The step motor must be used through the enclosed supplied controller STI ref. AD22255 (and relevant driver TRINAMIC model TCM-035).
- The supply circuits must be protect in case of current exceeding the limits fixed The user has to ensure prior to start up and during operation that the pressure transducers are correctly fixed inside the enclosure all the time.
- The rated values for pressure transducer must be guarantee.
- Pressure range of the medium has to be between 0.8 to 1.1 bar. Outside of this condition the approval on which this manual is based is only a guide.



1.2.2 Maintenance

- Must be done by qualified person who is trained to operate into potentially explosive atmosphere.
- Tools and equipment must be suitable for potentially explosive atmosphere where the actuator is installed.
- Cleaning must be done with a humid cloth.
- Greases and oils must be used according to the manufacturer's instructions, however their



INSTRUCTION MANUAL DPS (DIGITAL POSITION SYSTEM) QT series (motor)



flammability point must be > 140°C.



Do not remove the cylindrical joints before start up and during operation it must be ensured that all the three pressure transducers are correctly fixed inside the enclosure pos. 16 fig. 4 for any reason otherwise the flame proof gap is compromised.

2. GENERAL FEATURES

The step-motor enclosure mod. DPS™III is composed by an enclosure in which a step-motor and 3 pressure transducers are installed and a cover. On the step-motor's shaft an extension shaft equipped with 2 rolling bearing is fitted.

O-ring gaskets between the enclosure and the cover and between the enclosure and the support columns are used in order to guarantee the protection degree of the enclosure.

TECHNICAL FEATURES	
This device meets requirements for CE conformity certification (CEI EN55022, CEI EN 50082-2)	
Ambient temperature :	T5 = -40° to +70°C T6 = -40° to +50°C
Step-motor electrical input parameters (with driver control): (POWERMAXII series M22NxxB)	- I _s (dc): 1.5A - V _s (dc): 40V
Step-motor mechanical output:	1 (360°) actuation/sec
Pressure transducer electrical / pneumatic features: (FUJIKURA model XFGM-3001MPGSR)	- I _{max} (dc): 10 mA - V _{max} (dc): 5V - P _{range} : 0÷10 bar
Encoder supply voltage :	5V
Driver electrical input parameters: (TRINAMIC model TMCM-035)	- V _o (dc): 40V - I _o (dc): 3A
Conduit entries :	N°2 holes 3/4" NPT F



INSTRUCTION MANUAL DPS (DIGITAL POSITION SYSTEM) QT series (motor)

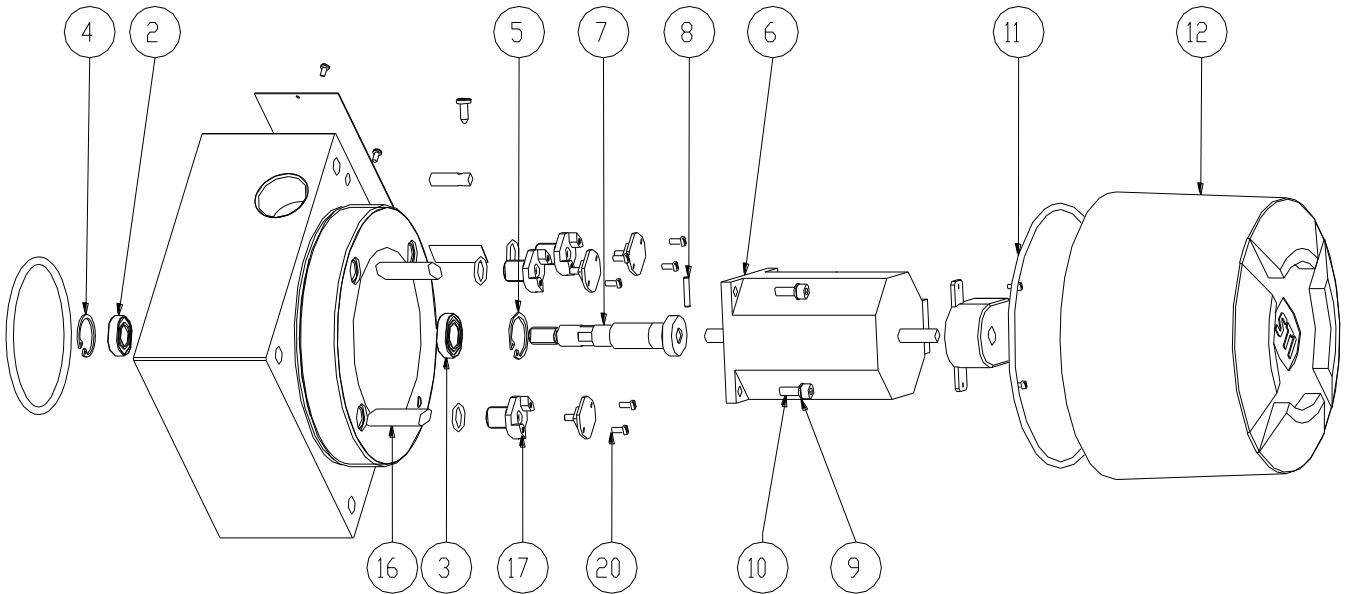

fig. 4 – Motor enclosure components

MATERIAL	
Housing:	EN AW 2011 T6 EN573-3
Cover [12]:	A356-T6
Shaft extension [7] :	X5CrNi 18 10 EN10088-3(ANSI304)
Rolling bearing [3-2]:	Stainless steel
Column supports for pressure transducers [17]:	EN AW 2011 T6 EN573-3
Flameproof joint [16]	X5CrNi 18 10 EN10088-3(ANSI304)

3. MOUNTING PROCEDURE

The step-motor is supplied with a stem extension pos.7 connected by a pin pos. 8 to its shaft:



Do not remove the pin pos. 8 for any reason.

For mounting or dismounting operation, follow these instructions (see above picture):

- mount rolling bearing pos. 2 in its appropriate seat and then clip pos. 4;
- mount rolling bearing pos. 3 in its appropriate seat and then clip pos. 5;
- insert step-motor pos. 6 inside the enclosure, taking care not to make an excessive axial force on the step-motor's shaft; fix the step-motor to the enclosure by the 4 screws pos. 9-10;
- insert N°3 flame proof joint pos. 16 inside the corresponding holes;
- mount N°3 O-rings and screw the pressure transducers support columns pos. 17 inside the corresponding holes;
- mount O-ring pos. 11;
- screw the cover pos. 12.

For the cables wiring refer to relevant electric diagram.

4. MAINTENANCE OPERATION



No maintenance operations are required on the stepping motor. In case of abnormal noise or malfunction contact STI.



**INSTRUCTION MANUAL
DPS (DIGITAL POSITION SYSTEM)
QT series (motor)**



Information in this manual is protected by copyright. All rights are reserved. No part of this manual and relevant mentioned and/or enclosed documentation may be reproduced without written authorization by **STI S.r.l.**

STI S.r.l. is not responsible for possible damage to people, equipment or data which might arise from incorrect use of the product to which the manual is referred.

Information in this document may be modified at any time without notice.



INSTRUCTION MANUAL DPS (DIGITAL POSITION SYSTEM) QT series (controller)



INDEX

1.0	General prescriptions	2
1.1	Manufacturer's identification data	2
1.2	General safety instructions	2
1.2.1	Installation	2
1.2.2	Maintenance	3
2.0	General features	3
3.0	Mounting procedure	4
4.0	Maintenance operation	5
5.0	Power board connection	5
5.1	Stepper motor wiring	5
5.2	Input and output signal wiring	6
5.3	Position demand : pin 1,2	6
5.4	4-20mA output : pin 3,4 & 5,6	6
5.5	Trip signals	7
5.6	Configurations and connections of trip signal	7
5.7	Supply wiring	8
5.8	Fuses	8
5.9	Digital output (J11)	8
5.10	Digital out1	8
5.11	Digital out2 &3	9
5.12	Solenoid valve sov (J9)	9
5.13	3xon/off solenoid valve driver characteristics	9
5.14	Solenoid valve connections	9
6.0	Display board connections	9
6.1	Pressure sensors and encoder connections	10
6.1.1	Feedback probe	10
6.1.2	Start/stop input	10
6.1.3	LVDT input	11
6.2	4-20mA input	11

1 GENERAL PRESCRIPTIONS



It is strongly recommended that this entire manual be read before attempting to install and operate the system.



1.1 MANUFACTURER'S IDENTIFICATION DATA

Every controller mod. DPS is provided with a name plate with its serial number. The year of manufacturing is indicated by the first two numbers of the serial number.

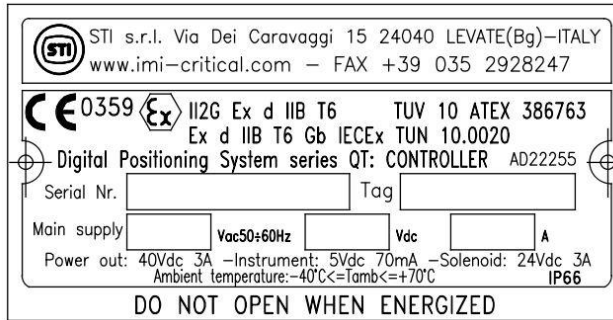

fig. 1 -Sample of equipment label



Do not remove it and/or replace with other name plates.

The controller mod. DPS, in its explosion proof version, is designed to operate in potentially explosive atmosphere ATEX/IECEx classified as:



**II 2 G Ex d IIB T6
Ex d IIB T6 Gb**

Equipment group II surface industry, category 2 for use in zone 1 with explosive atmospheres caused by gases, vapours or mists and in conformity to types of protection standardized EN60079-0 and IEC60079-0 with flameproof enclosure EN60079-1 and IEC60079-1 for hydrogen and acetylene (temperature class maximum 85°C).

Range of the permissible ambient temperature are: -40°÷ 70°C for T6.

1.2 GENERAL SAFETY INSTRUCTIONS



The non-observation of the following safety instruction and of the instruction manuals brings with it danger of explosions with serious injury or operator death.

1.2.1 INSTALLATION

- Must be done by qualified person who is trained to operate into potentially explosive atmosphere
- An external ground connection is mandatory, the section of the conductor must be chosen in accordance to EN60079-0 and IEC60079-0 (a M5 screw is available for the connection).

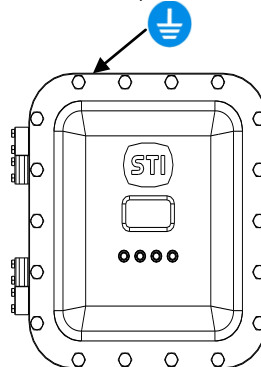

fig. 2 - External ground connection



INSTRUCTION MANUAL DPS (DIGITAL POSITION SYSTEM) QT series (controller)



- The electrical connections must be done according to the diagram and label.
- The equipment must be provided with cable entries and filler plugs certified according to the directive 94/9/EC, EN60079-0, IEC60079-0, EN60079-1 and IEC60079-1 for category 2G.
- The internal ground connection is mandatory, the section of the conductor must be chosen in accordance to EN60079-0 and IEC60079-0 (a M5 screw is available for the connection).
- The actuator must be installed and used according to the project design specification.
- The fluid must be chemically compatible with the used gaskets and lubricant.
- The supply circuits must be protected in case of current exceeding the limits fixed.



1.2.2 MAINTENANCE

- Must be done by qualified person who is trained to operate into potentially explosive atmosphere.
- Tools and equipment must be suitable for potentially explosive atmosphere where the actuator is installed.
- Cleaning must be done with a humid cloth.

2. GENERAL FEATURES

The controller mod. DPS is composed by an enclosure in which are housed a power supply, terminal blocks, display, local controls and a digital controller provides closed-loop control of valve position based upon input signal, valve position feedback, spool position feedback, and stepper-motor control.

The Digital Controller can be mounted directly to the actuator or remote-mounted.

O-ring gaskets between the enclosure and the cover and between the enclosure and the support columns are used in order to guarantee the IP protection degree of the enclosure.

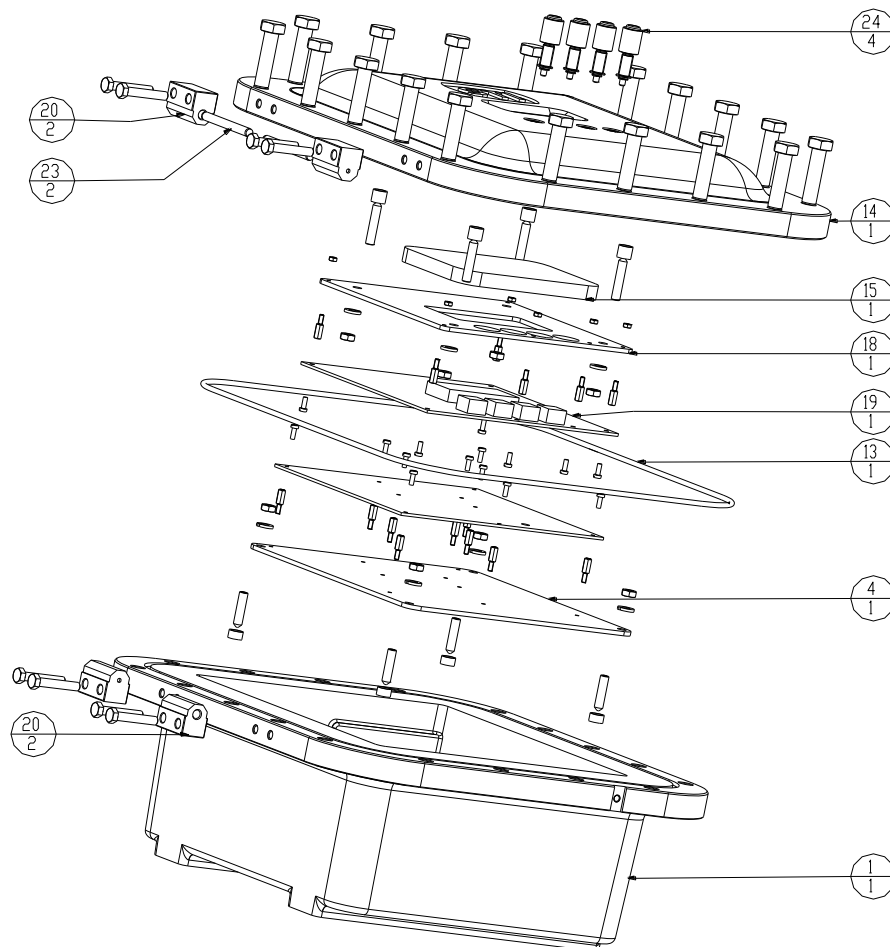

fig. 3 – Controller components



INSTRUCTION MANUAL DPS (DIGITAL POSITION SYSTEM) QT series (controller)



TECHNICAL FEATURES

This device meets requirements for CE conformity certification. Basic technical specifications: CEI EN55022, CEI EN 50082-2.

Input Signal / Position Feedback.....	4-20 mA; Hart protocol
Ambient temperature :	T6 = -40° to +70°C
Maximum power consumption.....	P _o : 95W
Power supply:.....	From 100 to 240 Vac ±10% 50-60Hz ±5% From 24 to 145 Vdc ±10% (0.3 to 4A)
Conduit entries :	see relevant drawing

MATERIAL

Housing [1] :	Aluminum G-AISI 9 MnMg UNI3051 or ASTM A356-T6
Cover [14] :	Aluminum G-AISI 9 MnMg UNI3051 or ASTM A356-T6
Hinghe [20] :	Aluminum 2011 UNI9002/5
Window [15] :	Glass
Push button [24] :	Aluminum 2011 UNI9002/5 or AISI 304
Support plate [4-18] :	AISI 303/304

3. MOUNTING PROCEDURE



CAUTION: The electrical and pneumatic connections must be done according to the diagram and label.



The controller enclosure is rated for IP66 environment. Outdoor mounting is acceptable, however, the controller should be protected from direct sunlight by a suitable shade (see temperature rating). For proper reading of the LCD screen, the controller should be mounted with the pushbuttons below the screen. The controller should be mounted securely to a sturdy mechanical surface using four screws in the enclosure mounting flange holes, with washers. See figure below for hole size and position. The structure, at the controller mounting location, should not be subjected to temperatures higher than the maximum ambient temperature described above.



WARNING: Additional holes on the enclosure not provided in the drawing PD21637 are not allowed, the non-observation brings with it danger of explosions with serious injury or operator death.

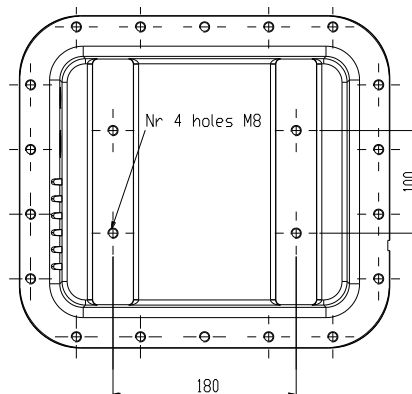



INSTRUCTION MANUAL DPS (DIGITAL POSITION SYSTEM) QT series (controller)



4. MAINTENANCE OPERATION

No maintenance operations are required on the controller.



WARNING: If the communications mode via RS-232 serial interface is required, be careful that the controller can be opened only when the unit is in a non hazardous environment.

5. POWER BOARD CONNECTION

The connections to the power board terminals are made through screw-type terminal blocks on the printed circuit boards. The recommended torque for these screws is 4.5 lb-in / 0.5 Nm for all terminal boards (max wires section 2,5mm²) except the terminal board J4 and J9 for which the recommended torque is 1.95 lb-in / 0.22Nm (max wires section 1,5mm²).

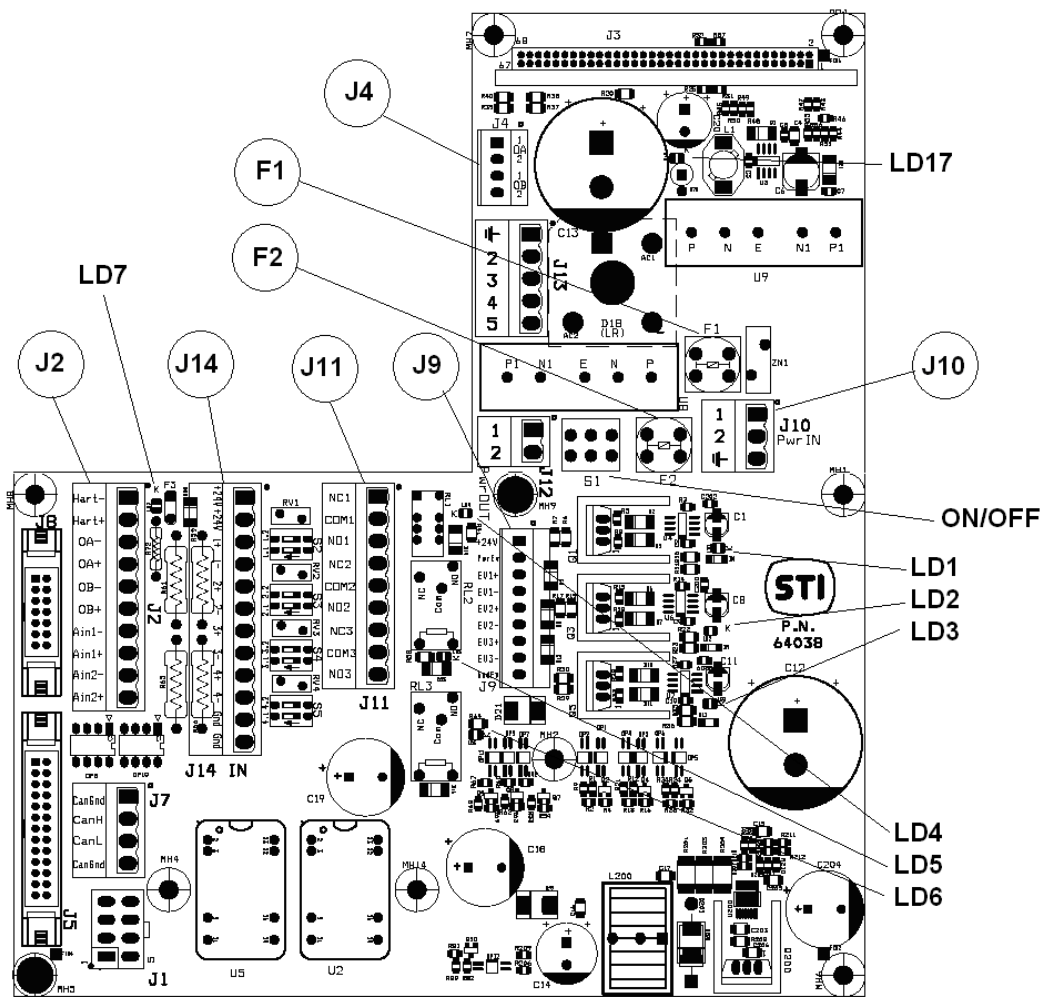

5.1 STEPPER MOTOR WIRING

J4 (already wired by the manufacturer) is the stepper motor connection (terminals 1-2-3-4).

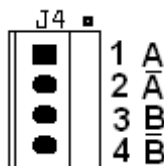



INSTRUCTION MANUAL DPS (DIGITAL POSITION SYSTEM) QT series (controller)



5.2 INPUT AND OUTPUT SIGNAL WIRING

J2

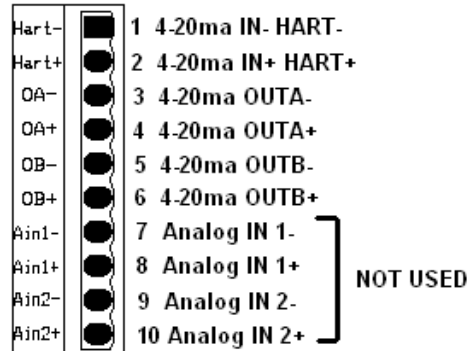

5.3 POSITION DEMAND : Pin 1,2

Input current, nominal	4-20ma
Input burden	475 Ω
Resolution	16 bit
Isolation Voltage	2500 V
HART revision	06
4-20ma input for position demand take power from an isolated source supplied from the controller	

5.4 4-20mA OUTPUT : Pin 3,4 & 5,6

Isolation voltage	2500V
Output current (nominal)	4-20ma
Burden	750 Ω max (power supply = 24Vdc)
External power supply	24V (12..30V)
Resolution	12 bit

Each 4-20mA output must be powered from the field.

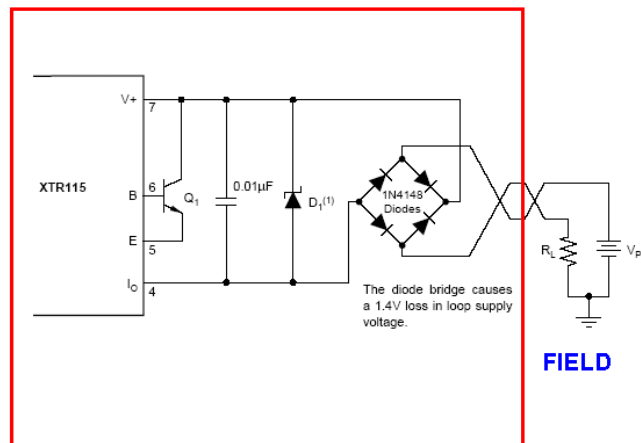



INSTRUCTION MANUAL DPS (DIGITAL POSITION SYSTEM) QT series (controller)



5.5 TRIP SIGNALS

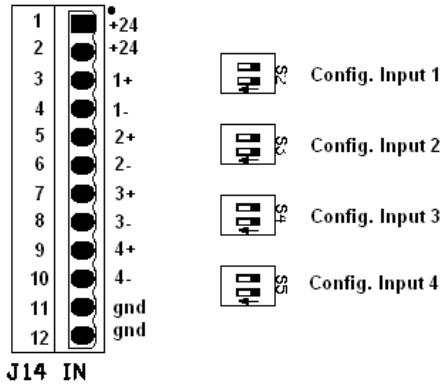

J14 Terminals are the input for trip signals.
Isolation voltage 2500V
Input type : Free contact or 24Vac or 24Vdc
The led LD1, LD2, LD3, LD4 mounted on the display board show the status of the trip signal.

5.6 CONFIGURATIONS AND CONNECTIONS OF TRIP SIGNAL

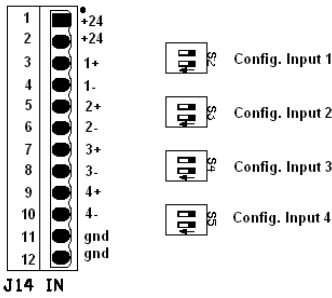

Examples (referred to TRIP1)

Configuration 1 : Free contact or NPN

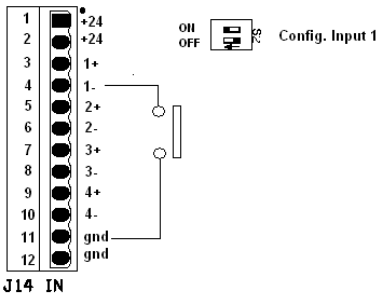

Configuration 2 : 24Vac/Vdc

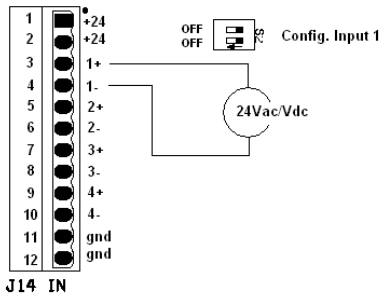

Configuration 3 : Free contact or PNP

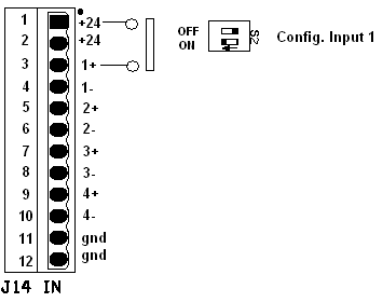



INSTRUCTION MANUAL DPS (DIGITAL POSITION SYSTEM) QT series (controller)



5.7 SUPPLY WIRING

There are different adapters for AC and DC electrical power.

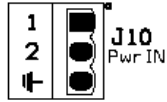

AC power : Standard available are 120 Vac and 240 Vac for alternate current power.

J10	
1	AC
2	AC
3	EARTH

DC power : Standard available are 24Vdc, 48Vdc, 110Vdc.

J10	
1	DC in +
2	DC in -
3	EARTH

5.8 FUSES

Supply / Fuse	F1	F2
120 Vac	800mA T	800mA T
240 Vac	400mA T	400mA T
24Vdc	5A T	5A T
48Vdc	2,5A T	2,5A T
110Vdc	2A T	2A T

When the led LD17 is ON, it shows that the electronic board is powered.

5.9 DIGITAL OUTPUT (J11)

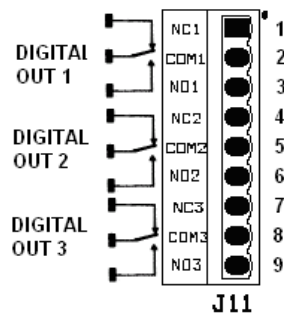

5.10 DIGITAL OUT1

■ Contact Ratings

Load	Resistive load (cosφ = 1)
Rated load	0.5 A at 125 VAC; 2 A at 30 VDC
Contact material	Ag (Au-clad)
Rated carry current	2 A
Max. switching voltage	250 VAC, 220 VDC
Max. switching current	2 A
Max. switching power	62.5 VA, 60 W
Min. permissible load	10 μA at 10 mVDC



INSTRUCTION MANUAL DPS (DIGITAL POSITION SYSTEM) QT series (controller)



5.11 DIGITAL OUT2 &3

CONTACT DATA	
Contact arrangement	1A, 1C
Initial contact resistance Max.	100mΩ (at 1A 6VDC)
Contact material	See ordering info.
Contact rating (Res. load)	NO: 5A 250VAC/30VDC NC: 3A 250VAC/30VDC
Max. switching voltage	250VAC / 30VDC
Max. switching current	5A
Max. switching power	1250VA / 150W

The led LD4, LD5, LD6 mounted on the power board show the status of the digital output 1, 2, 3 respectively.

5.12 SOLENOID VALVE SOV (J9)

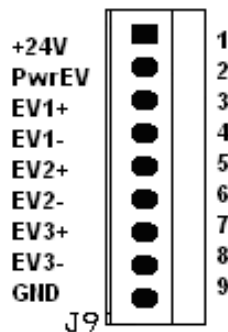

5.13 3xON/OFF SOLENOID VALVE DRIVER CHARACTERISTICS

High side solenoid driver
PWM capability for power reduction
Short circuit proof
Up to 2000mA

The led LD1, LD2, LD3 mounted on the power board show the status of the EV1, EV2, EV3 respectively.

The led LD7 shows that the presence of the 24VDC power.

5.14 SOLENOID VALVE CONNECTIONS

Connect pin 1 and 2 of J9. This makes available the internally produced 24Vdc to the solenoid valves.

Connect SOV1 to pin 3 and 4.

Connect SOV2 to pin 5 and 6.

Connect SOV3 to pin 7 and 8.

6 DISPLAY BOARD CONNECTIONS

The connections to the controller are made through screw-type terminal blocks on the printed circuit boards. The recommended torque for these screws is 1.95 lb-in / 0.22Nm (max wires section 1,5mm²).



INSTRUCTION MANUAL DPS (DIGITAL POSITION SYSTEM) QT series (controller)

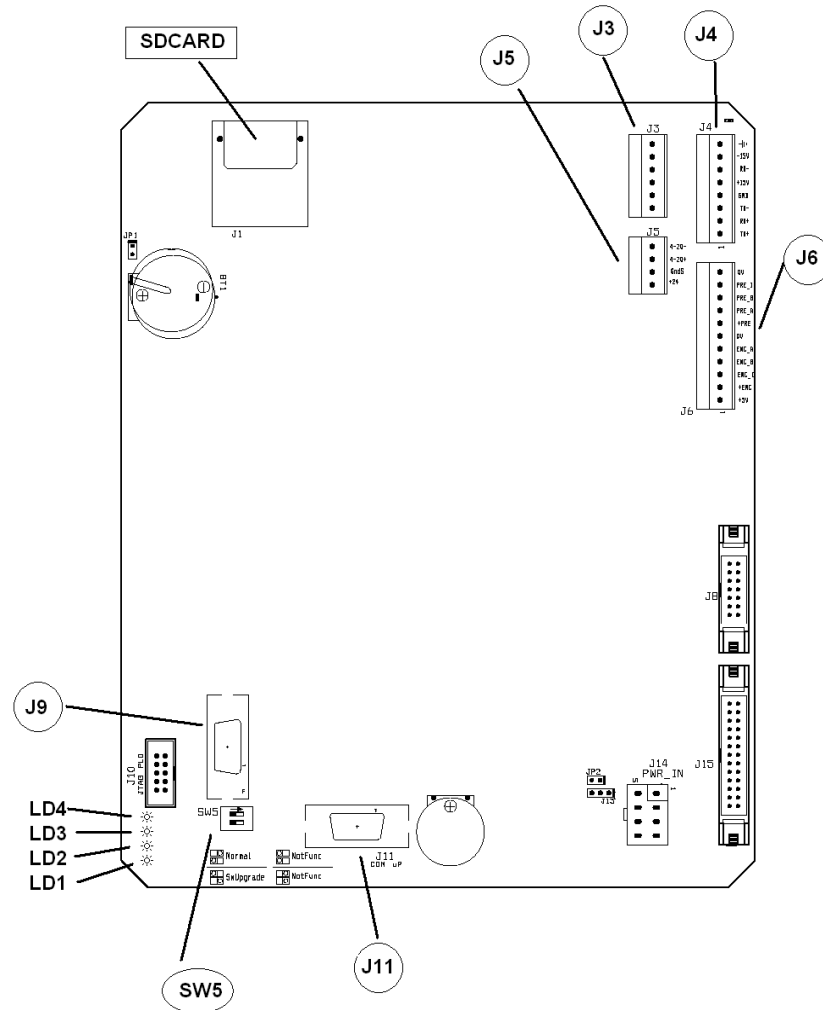

6.1 PRESSURE SENSORS AND ENCODER CONNECTIONS

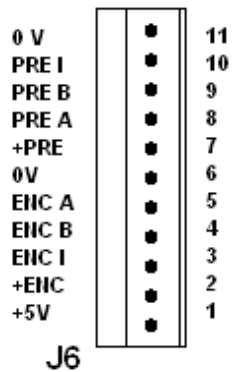

Use always pin1 (+5V) to power the pressure sensors.

6.1.1 FEEDBACK PROBE

Three different models of feedback probes can be used

6.1.2 START/STOP INPUT

Balluff Micropulse trasducer or equivalent can be used.



INSTRUCTION MANUAL DPS (DIGITAL POSITION SYSTEM) QT series (controller)



For this probe the power supply is +/- 15V.

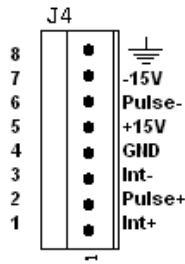

6.1.3 LVDT INPUT

LVDT type : 4 wires
Resolution : 16 bit

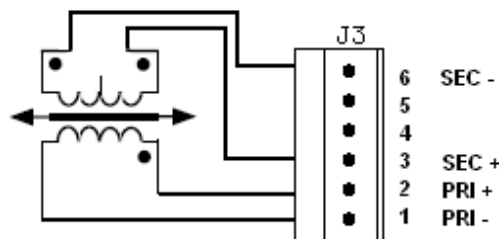

Pin 1 e 2 : primary circuit connection

Pin 3 e 6 : secondary circuit connection

Pin 4 e 5 : they are internally connected on the board and they can be used (if needed) for the secondary circuit connection

6.2 4-20mA INPUT

Input current, nominal : 4-20mA
Input burden : 475 Ω
Resolution : 16 bit
Isolation Voltage : 2500 V

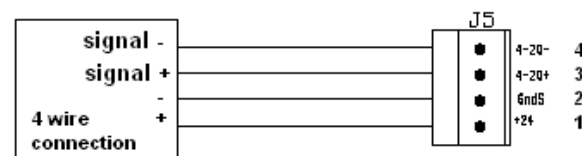
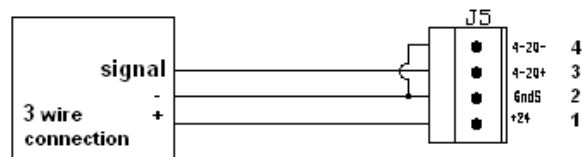
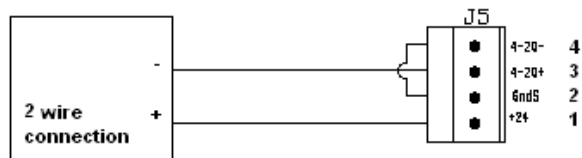



**INSTRUCTION MANUAL
DPS (DIGITAL POSITION SYSTEM)
QT series (controller)**



Information in this manual is protected by copyright. All rights are reserved. No part of this manual and relevant mentioned and/or enclosed documentation may be reproduced without written authorization by **STI S.r.l.**

STI S.r.l. is not responsible for possible damage to people, equipment or data which might arise from incorrect use of the product to which the manual is referred.

Information in this document may be modified at any time without notice.



INSTRUCTION MANUAL DPS (DIGITAL POSITION SYSTEM) QT series (Spool valve CV9)



INDEX

1.0	Fail mode operation	2
1.1	CV9 Fail-Open, Fail-Close or Fail-In Place	2
2.0	Spool valve manifold CV9	3
2.1	To remove the device from the actuator	3



INSTRUCTION MANUAL DPS (DIGITAL POSITION SYSTEM) QT series (Spool valve CV9)



1.0 FAIL MODE OPERATION

DPS series QT will fail on loss of power, loss of air supply or loss of signal.

- Loss of power: causes the Digital Controller to trip the Solenoid Valve for Fail Mode.
- Loss of air supply: is detected by a pressure transducer in the Servo-Valve; the Digital Controller trips the Solenoid Valve for Fail Mode when the air pressure drops below a set point in the Controller software.
- Loss of signal: causes the Digital Controller to position the valve at its fail position.

1.1 CV 9 Fail-Open, Fail-Close or Fail-In Place

The CV 9 model uses standard STI 3 or 2 ways valve (size 1"1/2) which drives the Servo-Valve to Fail-Open, Fail-Closed or Fail-In Place. The 3 or 2 ways valves (3W or 2W) are piloted by a 24Vdc solenoid valve (SOV). The solenoid valve (SOV) is piloted by the Digital Controller (C).

For further details on schematic and fail mode, please refer to the specific project documentation.

FAIL IN

ITEM	DESCRIPTION
A	ACTUATOR
AFR	AIR FILTER REGULATOR
SOV	SOLENOID VALVE
C	CONTROL CABINET
S	SERVO VALVE
B	CHECK VALVE
2W	2 WAYS VALVE
PT	PRESSURE TRANSDUCER
Z	FEEDBACK PROBE
UC	UMBILICAL CABLE

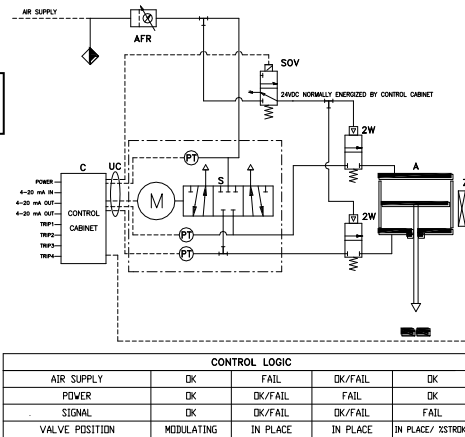

FAIL OPEN

ITEM	DESCRIPTION
A	ACTUATOR
AFR	AIR FILTER REGULATOR
SOV	SOLENOID VALVE
C	CONTROL CABINET
S	SERVO VALVE
AB	AIR BOTTLE
B	CHECK VALVE
3W	3 WAYS VALVE
PT	PRESSURE TRANSDUCER
Z	FEEDBACK PROBE
UC	UMBILICAL CABLE

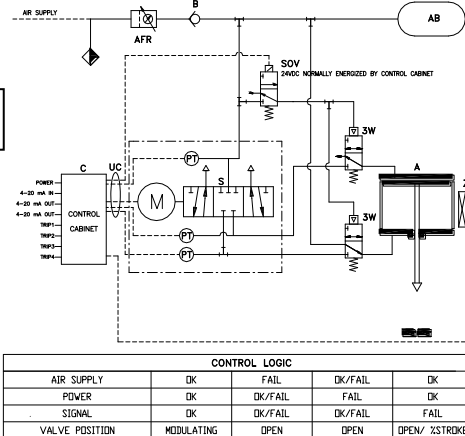

FAIL

ITEM	DESCRIPTION
A	ACTUATOR
AFR	AIR FILTER REGULATOR
SOV	SOLENOID VALVE
C	CONTROL CABINET
S	SERVO VALVE
AB	AIR BOTTLE
B	CHECK VALVE
3W	3 WAYS VALVE
PT	PRESSURE TRANSDUCER
Z	FEEDBACK PROBE
UC	UMBILICAL CABLE

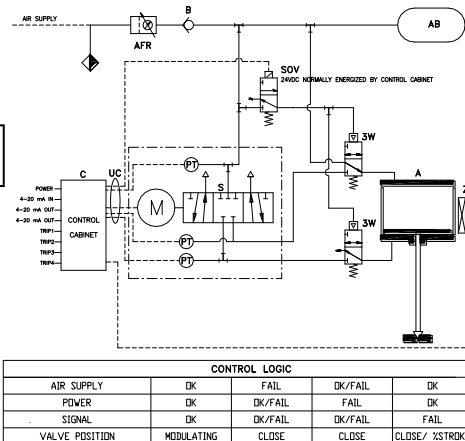



INSTRUCTION MANUAL DPS (DIGITAL POSITION SYSTEM) QT series (Spool valve CV9)



2.0 SPOOL VALVE MANIFOLD CV9

No maintenance operations are required on the spool valve manifold. In case of abnormal noise or malfunction contact STI.

2.1 To remove the device from the actuator:

- disconnect the supply line from the manifold and all electrical conduit;
- unscrew the 8 nuts on the tie rod (pos. A);
- remove the device from the actuator.

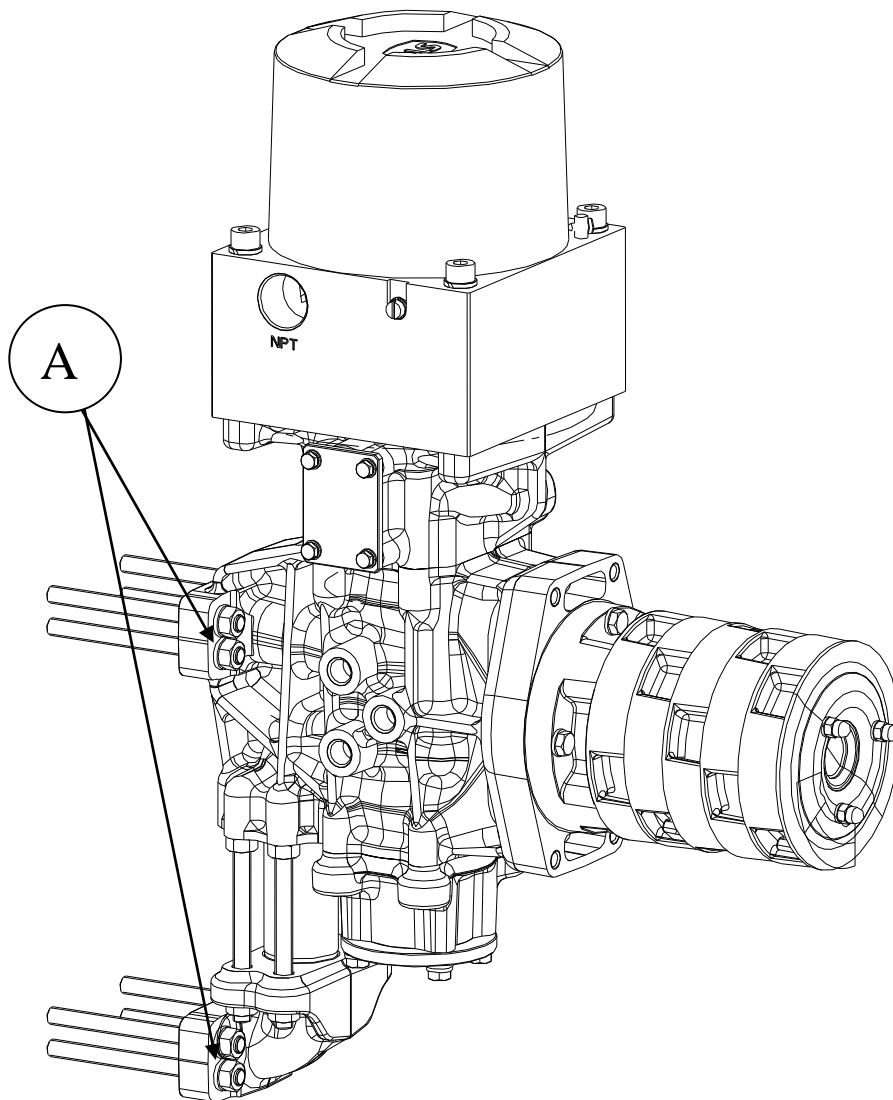

Information in this manual is protected by copyright. All rights are reserved. No part of this manual and relevant mentioned and/or enclosed documentation may be reproduced without written authorization by **STI S.r.l.**

STI S.r.l. is not responsible for possible damage to people, equipment or data which might arise from incorrect use of the product to which the manual is referred.

Information in this document may be modified at any time without notice.



INSTRUCTION MANUAL DPS (DIGITAL POSITION SYSTEM) QT series (Spool valve CV30)



INDEX

1.0	Fail mode operation	2
1.1	CV30 Fail-Open, Fail-Close or Fail-In Place	2
2.0	Spool valve manifold CV30	3
2.1	To remove the device from the actuator	3



INSTRUCTION MANUAL DPS (DIGITAL POSITION SYSTEM) QT series (Spool valve CV30)



1.0 FAIL MODE OPERATION

DPS series QT will fail on loss of power, loss of air supply or loss of signal.

- Loss of power: causes the Digital Controller to trip the Solenoid Valve for Fail Mode.
- Loss of air supply: is detected by a pressure transducer in the Servo-Valve; the Digital Controller trips the Solenoid Valve for Fail Mode when the air pressure drops below a set point in the Controller software.
- Loss of signal: causes the Digital Controller to position the valve at its fail position.

1.1 CV 30 Fail-Open, Fail-Close or Fail-In Place

The CV 30 model uses standard STI 3 or 2 ways valve (size 2") which drives the Servo-Valve to Fail-Open, Fail-Closed or Fail-In Place. The 3 or 2 ways valves (3W or 2W) are piloted by a 24Vdc solenoid valve (SOV). The solenoid valve (SOV) is piloted by the Digital Controller (C).

For further details on schematic and fail mode, please refer to the specific project documentation.

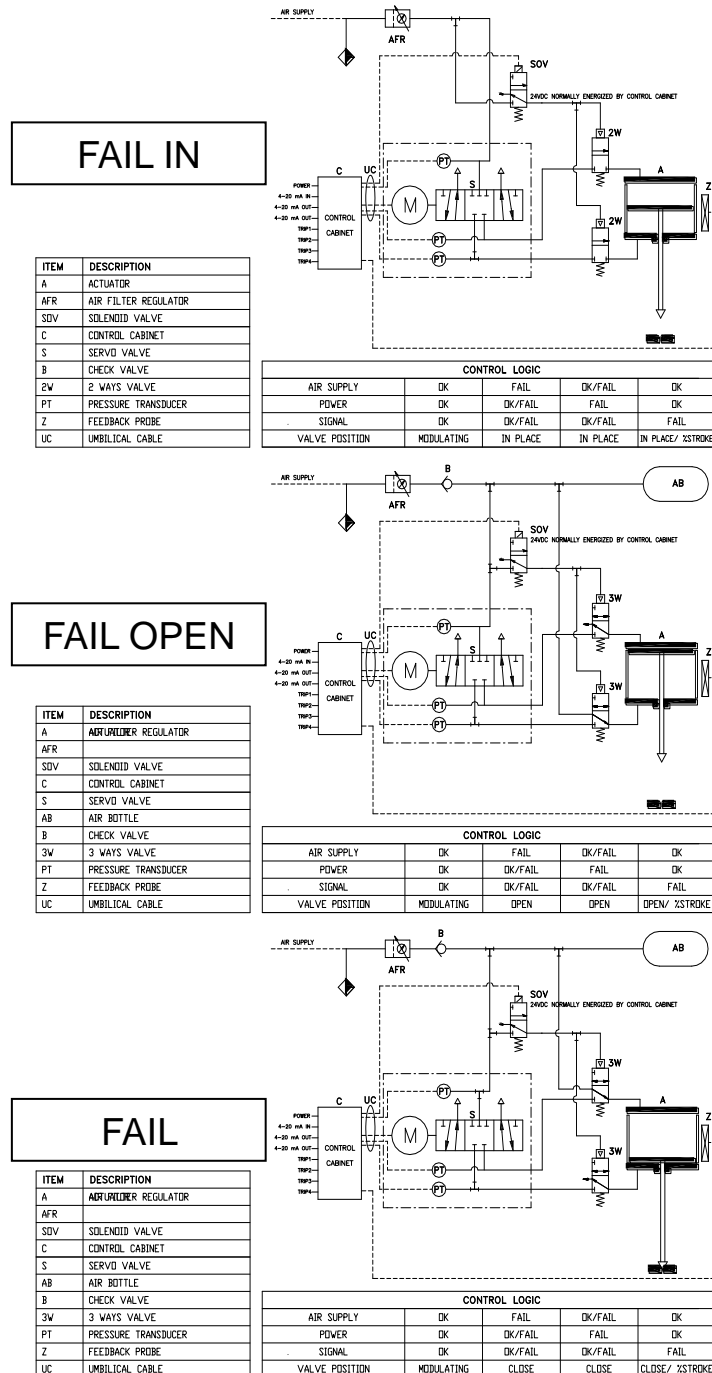



INSTRUCTION MANUAL DPS (DIGITAL POSITION SYSTEM) QT series (Spool valve CV30)



2.0 SPOOL VALVE MANIFOLD CV30

No maintenance operations are required on the spool valve manifold. In case of abnormal noise or malfunction contact STI.

2.1 To remove the device from the actuator:

- disconnect the supply line from the manifold and all electrical conduit;
- unscrew the 8 screws on the block (pos. A);
- remove the device from the actuator.

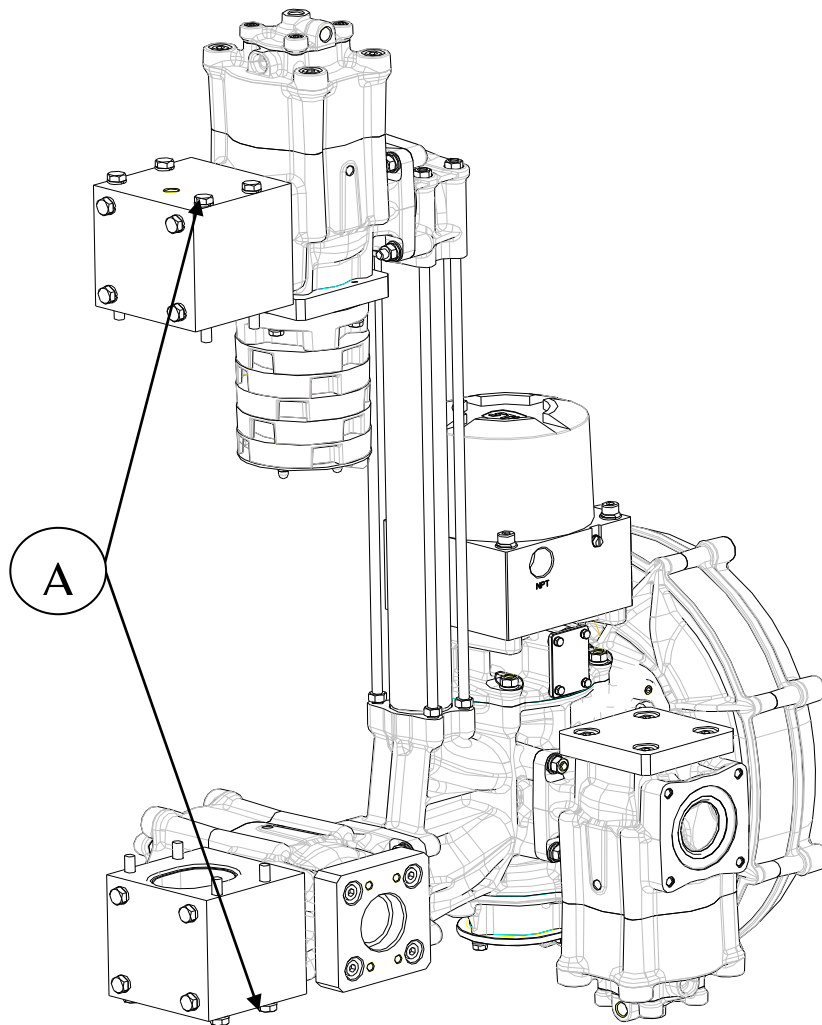

Information in this manual is protected by copyright. All rights are reserved. No part of this manual and relevant mentioned and/or enclosed documentation may be reproduced without written authorization by **STI S.r.l.**

STI S.r.l. is not responsible for possible damage to people, equipment or data which might arise from incorrect use of the product to which the manual is referred.

Information in this document may be modified at any time without notice.



INSTRUCTION MANUAL DPS (DIGITAL POSITION SYSTEM) QT series (controller)



INDEX

1.0	General prescriptions	2
1.1	Manufacturer's identification data	2
1.2	General safety instructions	2
1.2.1	Installation	2
1.2.2	Maintenance	3
2.0	General features	3
3.0	Mounting procedure	3
4.0	Maintenance operation	3
5.0	Power board connection	3
5.1	Stepper motor wiring	4
5.2	Input and output signal wiring	4
5.3	Position demand : pin 1,2	5
5.4	4-20mA output : pin 3,4 & 5,6	5
5.5	Trip signals	5
5.6	Configurations and connections of trip signal	6
5.7	Supply wiring	6
5.8	Fuses	7
5.9	Digital output (J11)	7
5.10	Digital out1	7
5.11	Digital out2 &3	7
5.12	Solenoid valve sov (J9)	8
5.13	3xon/off solenoid valve driver characteristics	8
5.14	Solenoid valve connections	8
6.0	Display board connections	8
6.1	Pressure sensors and encoder connections	9
6.1.1	Feedback probe	9
6.1.2	Start/stop input	9
6.1.3	LVDT input	10
6.2	4-20mA input	10

1 GENERAL PRESCRIPTIONS



It is strongly recommended that this entire manual be read before attempting to install and operate the system

1.1 MANUFACTURER'S IDENTIFICATION DATA



Every controller mod. DPS is provided with a name plate with its serial number. The year of manufacturing is indicated by the first two numbers of the serial number.

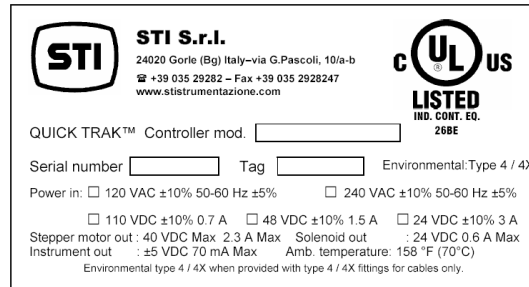

fig. 1 - Sample of equipment label



Do not remove it and/or replace with other name plates.

Range of the permissible ambient temperature are: $-40^{\circ} \div 70^{\circ}\text{C}$ for T6

1.2 GENERAL SAFETY INSTRUCTIONS

The non-observation of the following safety instruction and of the instruction manuals brings with it danger of explosions with serious injury or operator death.

1.2.1 INSTALLATION

- An external ground connection is present at the side of controller.

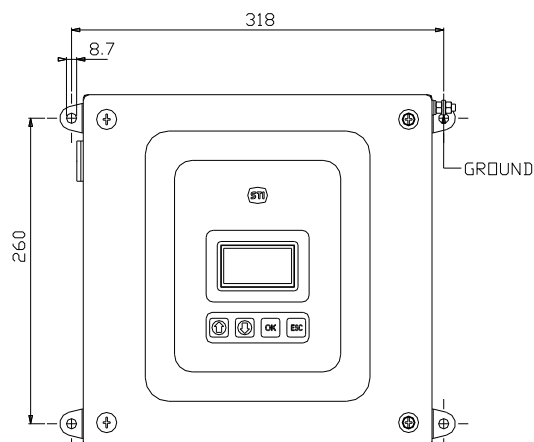

fig. 2 - External ground connection

- The electrical connections must be done according to the diagram and label.

- The internal ground connection is mandatory.
- The actuator must be installed and used according to the project design specification.
- The fluid must be chemically compatible with the used gaskets and lubricant.
- The supply circuits must be protect in case of current exceeding the limits fixed.



1.2.2 MAINTENANCE

- Must be done by qualified person who is trained to operate into potentially explosive atmosphere.
- Tools and equipment must be suitable for potentially explosive atmosphere where the actuator is installed.
- Cleaning must be done with a humid cloth.

2. GENERAL FEATURES

The controller mod. DPS is composed by an enclosure in which are housed a power supply, terminal blocks, display, local controls and a digital controller provides closed-loop control of valve position based upon input signal, valve position feedback, spool position feedback, and stepper-motor control.

The Digital Controller can be mounted directly to the actuator or remote-mounted.

O-ring gaskets between the enclosure and the cover and between the enclosure and the support columns are used in order to guarantee the IP protection degree of the enclosure.

TECHNICAL FEATURES	
This device meets requirements for CE conformity certification. Basic technical specifications: CEI EN55022; CEI EN 50082-2.	
Input Signal / Position Feedback.....	4-20 mA; Hart protocol
Ambient temperature :	T6 = -40° to +70°C
Maximum power consumption.....	P _o : 95W
Power supply:.....	From 100 to 240 Vac ±10% 50-60Hz ±5%
	From 24 to 240 Vdc ±10% (0.3 to 4A)
Conduit entries :	see relevant drawing

3. MOUNTING PROCEDURE



CAUTION: The electrical and pneumatic connections must be done according to the diagram and label



The controller enclosure is rated for IP66 environment. Outdoor mounting is acceptable, however, the controller should be protected from direct sunlight by a suitable shade (see temperature rating). For proper reading of the LCD screen, the controller should be mounted with the pushbuttons below the screen. The controller should be mounted securely to a sturdy mechanical surface using four screws in the enclosure mounting flange holes, with washers. See figure below for hole size and position. The structure, at the controller mounting location, should not be subjected to temperatures higher than the maximum ambient temperature described above.



4. MAINTENANCE OPERATION

No maintenance operations are required on the controller.



WARNING: If the communications mode via RS-232 serial interface is required, be careful that the controller can be opened only when the unit is in a non hazardous environment.

5 POWER BOARD CONNECTION

The connections to the power board terminals are made through screw-type terminal blocks on the printed circuit boards. The recommended torque for these screws is 4.5 lb-in / 0.5 Nm for all terminal boards (max wires section 2,5mm²) except the terminal board J4 and J9 for which the recommended torque is 1.95 lb-in / 0.22Nm (max wires section 1,5mm²).



INSTRUCTION MANUAL DPS (DIGITAL POSITION SYSTEM) QT series (controller)

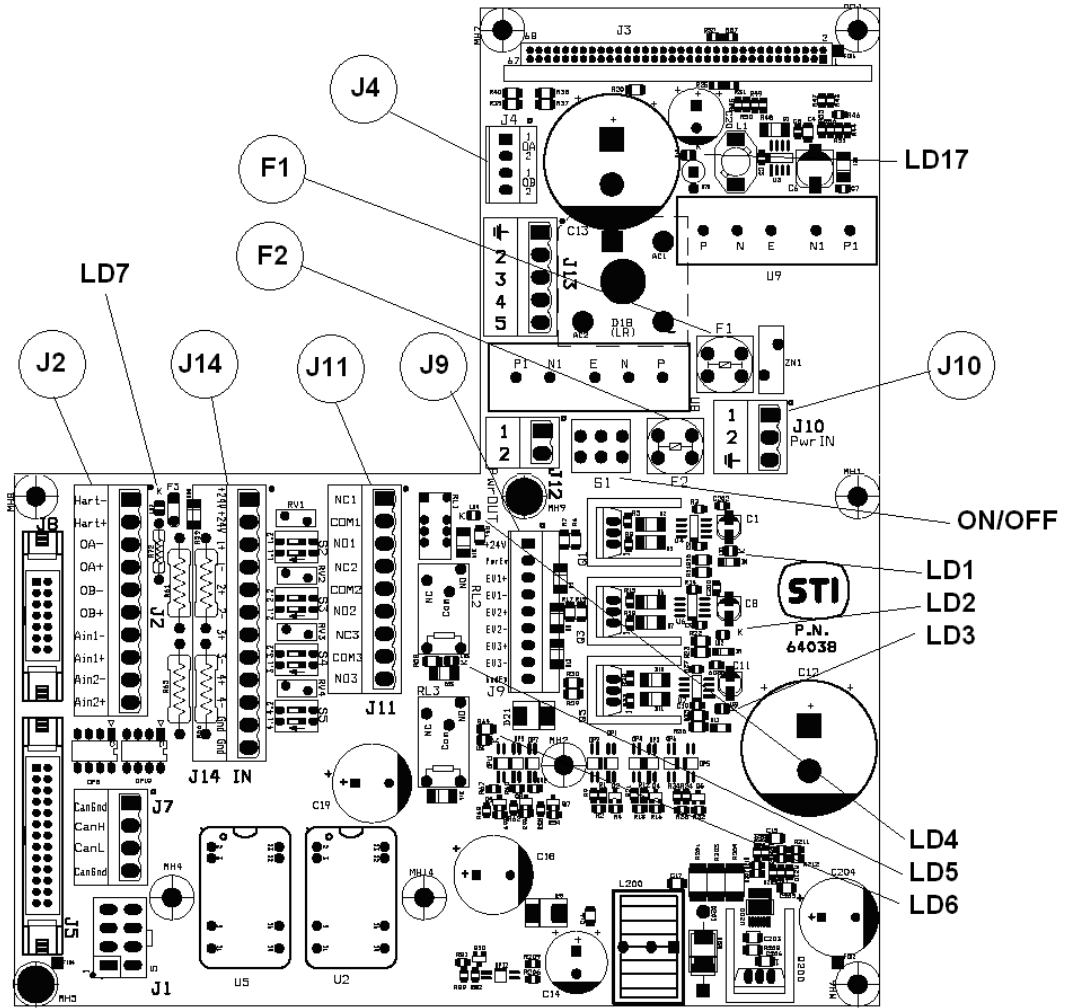

5.1 STEPPER MOTOR WIRING

J4 (already wired by the manufacturer) is the stepper motor connection (terminals 1-2-3-4).

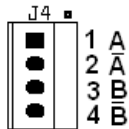

5.2 INPUT AND OUTPUT SIGNAL WIRING

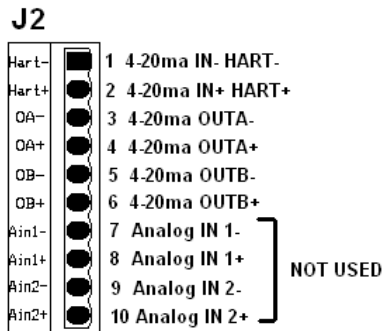



INSTRUCTION MANUAL DPS (DIGITAL POSITION SYSTEM) QT series (controller)



5.3 POSITION DEMAND : Pin 1,2

Input current, nominal	4-20mA
Input burden	475 Ω
Resolution	16 bit
Isolation Voltage	2500 V
HART revision	06
4-20mA input for position demand take power from an isolated source supplied from the controller	

5.4 4-20mA OUTPUT : Pin 3,4 & 5,6

Isolation voltage	2500V
Output current (nominal)	4-20mA
Burden	750 Ω max (power supply = 24Vdc)
External power supply	24V (12..30V)
Resolution	12 bit

Each 4-20mA output must be powered from the field.

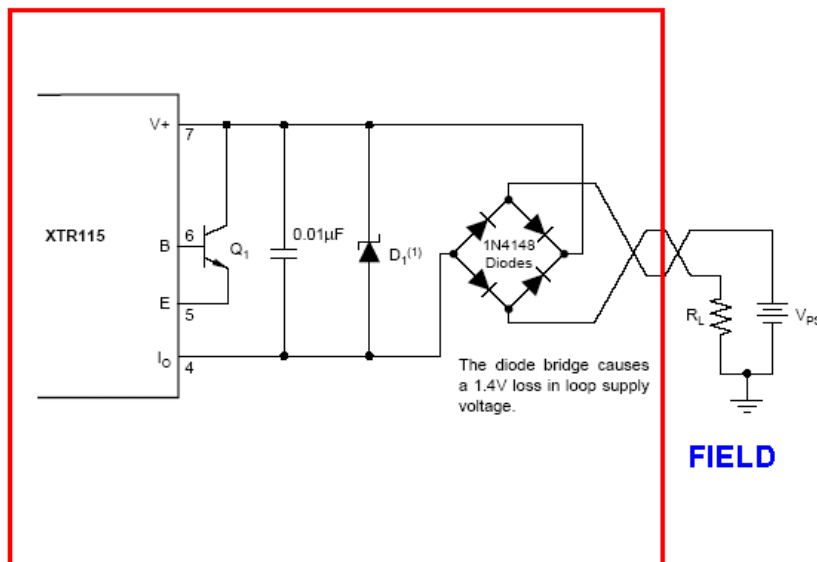

5.5 TRIP SIGNALS

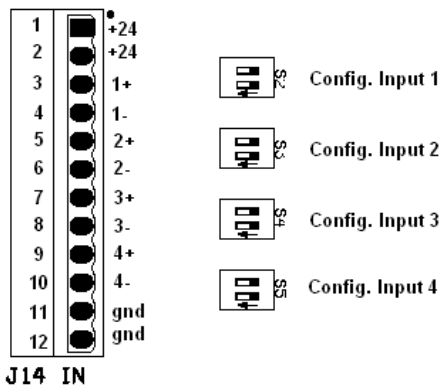

J14 Terminals are the input for trip signals.
Isolation voltage: 2500V
Input type : Free contact or 24Vac or 24Vdc
The led LD1, LD2, LD3, LD4 mounted on the display board show the status of the trip signal.



INSTRUCTION MANUAL DPS (DIGITAL POSITION SYSTEM) QT series (controller)



5.6 CONFIGURATIONS AND CONNECTIONS OF TRIP SIGNAL

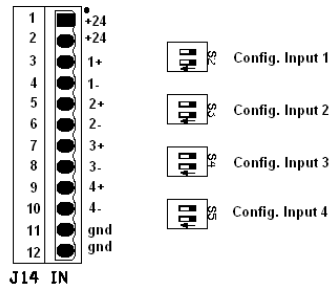

Examples (referred to TRIP1)

Configuration 1 : Free contact or NPN

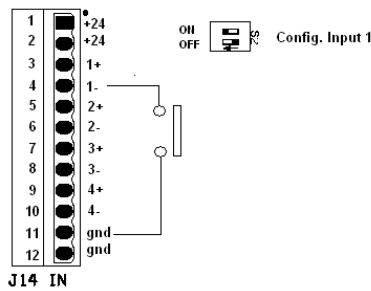

Configuration 2 : 24Vac/Vdc

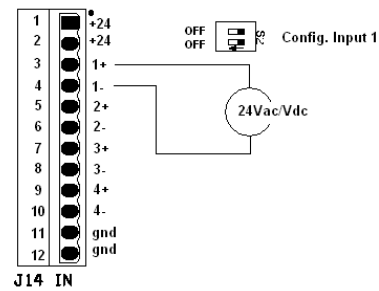

Configuration 3 : Free contact or PNP

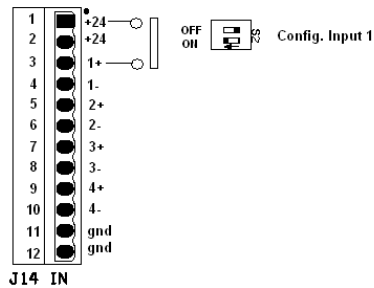

5.7 SUPPLY WIRING

There are different adapters for AC and DC electrical power.

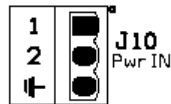

AC power : Standard available are 120 Vac and 240 Vac for alternate current power.

J10	
1	AC
2	AC
3	EARTH

DC power : Standard available are 24Vdc, 48Vdc, 110Vdc.

J10	
1	DC in +
2	DC in -
3	EARTH



INSTRUCTION MANUAL DPS (DIGITAL POSITION SYSTEM) QT series (controller)



5.8 FUSES

Supply / Fuse	F1	F2
120 Vac	800mA T	800mA T
240 Vac	400mA T	400mA T
24 Vdc	5A T	5A T
48 Vdc	2,5A T	2,5A T
110 Vdc	2A T	2A T

When the led LD17 is ON, it shows that the electronic board is powered.

5.9 DIGITAL OUTPUT (J11)

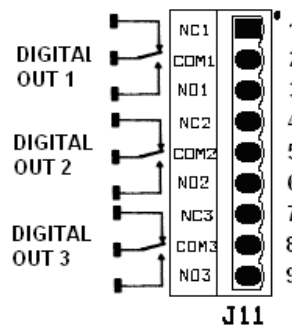

5.10 DIGITAL OUT1

■ Contact Ratings

Load	Resistive load (cosφ = 1)
Rated load	0.5 A at 125 VAC; 2 A at 30 VDC
Contact material	Ag (Au-clad)
Rated carry current	2 A
Max. switching voltage	250 VAC, 220 VDC
Max. switching current	2 A
Max. switching power	62.5 VA, 60 W
Min. permissible load	10 μA at 10 mVDC

5.11 DIGITAL OUT2 & 3

CONTACT DATA	
Contact arrangement	1A, 1C
Initial contact resistance Max.	100mΩ (at 1A 6VDC)
Contact material	See ordering info.
Contact rating (Res. load)	NO: 5A 250VAC/30VDC NC: 3A 250VAC/30VDC
Max. switching voltage	250VAC / 30VDC
Max. switching current	5A
Max. switching power	1250VA / 150W

The led LD4, LD5, LD6 mounted on the power board show the status of the digital output 1, 2, 3 respectively.



INSTRUCTION MANUAL DPS (DIGITAL POSITION SYSTEM) QT series (controller)



5.12 SOLENOID VALVE SOV (J9)

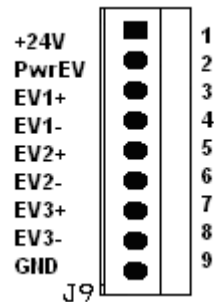

5.13 3xON/OFF SOLENOID VALVE DRIVER CHARACTERISTICS

High side solenoid driver

PWM capability for power reduction

Short circuit proof

Up to 2000mA

The led LD1, LD2, LD3 mounted on the power board show the status of the EV1, EV2, EV3 respectively.

The led LD7 shows that the presence of the 24VDC power.

5.14 SOLENOID VALVE CONNECTIONS

Connect pin 1 and 2 of J9. This makes available the internally produced 24Vdc to the solenoid valves.

Connect SOV1 to pin 3 and 4.

Connect SOV2 to pin 5 and 6.

Connect SOV3 to pin 7 and 8.

6 DISPLAY BOARD CONNECTIONS

The connections to the controller are made through screw-type terminal blocks on the printed circuit boards. The recommended torque for these screws is 1.95 lb-in / 0.22Nm (max wires section 1,5mm²).



INSTRUCTION MANUAL DPS (DIGITAL POSITION SYSTEM) QT series (controller)

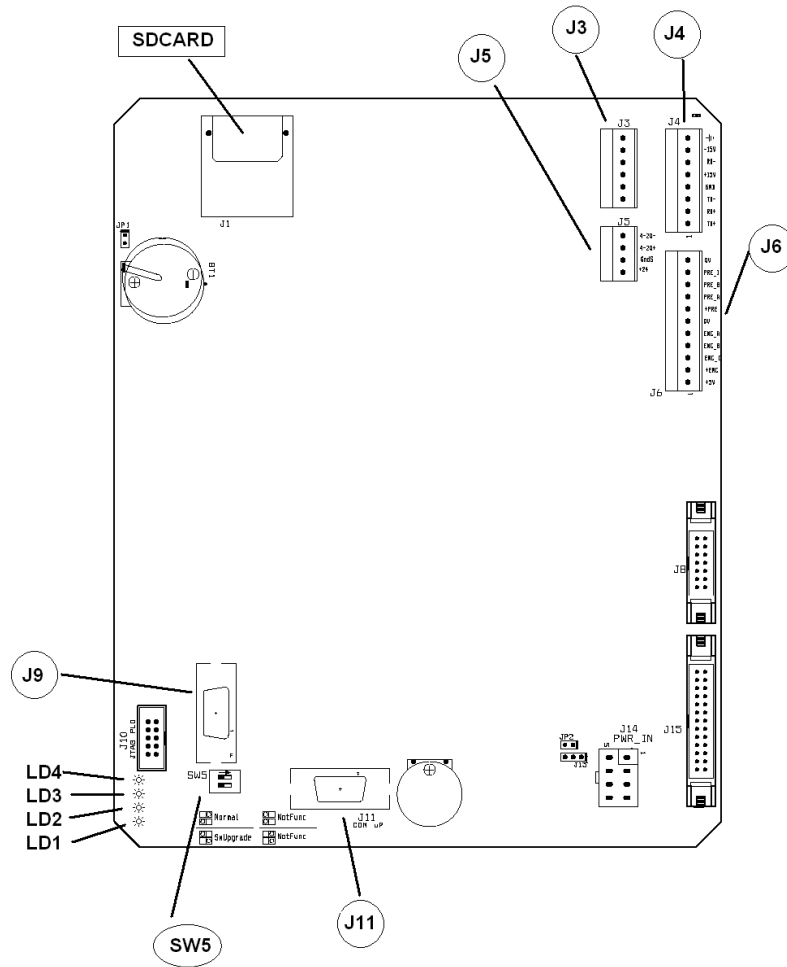

6.1 PRESSURE SENSORS AND ENCODER CONNECTIONS

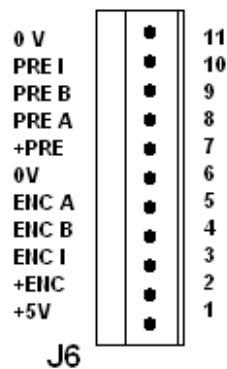

Use always pin1 (+5V) to power the pressure sensors.

6.1.1 FEEDBACK PROBE

Three different models of feedback probes can be used

6.1.2 START/STOP INPUT

Balluff Micropulse trasducer or equivalent can be used.
For this probe the power supply is +/- 15V



INSTRUCTION MANUAL DPS (DIGITAL POSITION SYSTEM) QT series (controller)

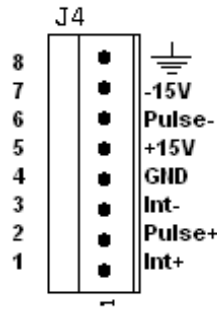

6.1.3 LVDT INPUT

LVDT type : 4 wires
Resolution : 16 bit

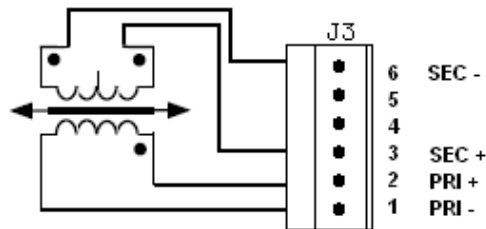

Pin 1 e 2 : primary circuit connection
Pin 3 e 6 : secondary circuit connection
Pin 4 e 5 : they are internally connected on the board and they can be used (if needed) for the secondary circuit connection

6.2 4-20mA INPUT

Input current, nominal : 4-20mA
Input burden : 475 Ω
Resolution : 16 bit
Isolation Voltage : 2500 V

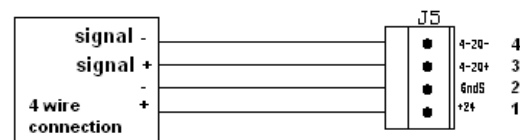
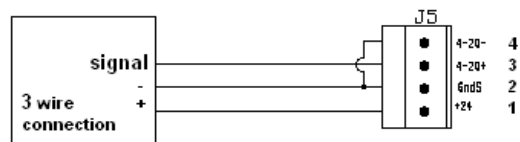
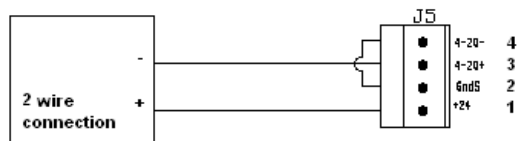



**INSTRUCTION MANUAL
DPS (DIGITAL POSITION SYSTEM)
QT series (controller)**



Information in this manual is protected by copyright. All rights are reserved. No part of this manual and relevant mentioned and/or enclosed documentation may be reproduced without written authorization by **STI S.r.l.**

STI S.r.l. is not responsible for possible damage to people, equipment or data which might arise from incorrect use of the product to which the manual is referred.

Information in this document may be modified at any time without notice.



INSTRUCTION MANUAL DPS (DIGITAL POSITION SYSTEM) QT series (motor)



INDEX

1.0	General prescription	2
1.1	Manufacturer's identification data	2
1.2	General safety instructions	2
1.2.1	Installation	2
1.2.2	Maintenance	3
2.0	General features	3
3.0	Mounting procedure	5
4.0	Maintenance operation	5

1 GENERAL PRESCRIPTIONS



Recommended that this entire manual be read before attempting to install and operate the system.

1.1 MANUFACTURER'S IDENTIFICATION DATA



Every step-motor enclosure mod. DPS is provided with a name plate with its serial number. The year of manufacturing is indicated by the first two numbers of the serial number.

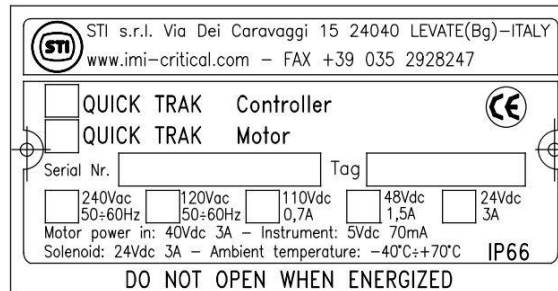

fig. 1 - Sample of equipment label

Manufacturing year is indicated by the two first digit number of the serial number.



Do not remove it and/or replace with other name plate.

Range of the permissible ambient temperature are:
-40°÷ 70°C

1.2 GENERAL SAFETY INSTRUCTIONS



The non-observation of the following safety instructions and of the instruction manuals ones brings with it danger of explosions with serious injury or operator's death.

1.2.1 Installation



- Must be done by qualified person trained to operate into potentially explosive atmosphere
- An external ground connection is present at the side of enclosure.
-

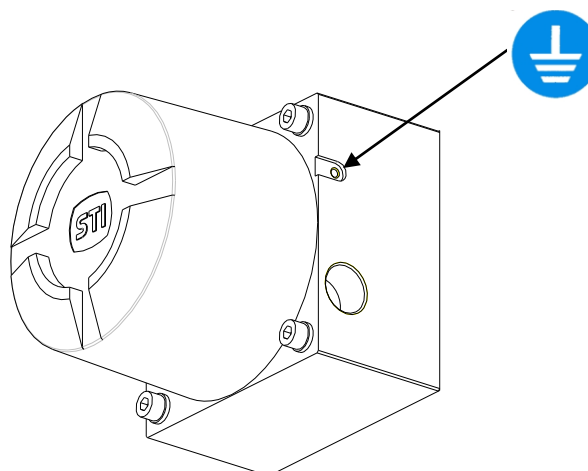

fig. 2 - External ground connection

- The electrical and pneumatic connections must be done according to the diagram and label.
- The supply circuit must be protected in case of current exceeding the limit fixed.
- The internal ground connection is mandatory.



INSTRUCTION MANUAL DPS (DIGITAL POSITION SYSTEM) QT series (motor)

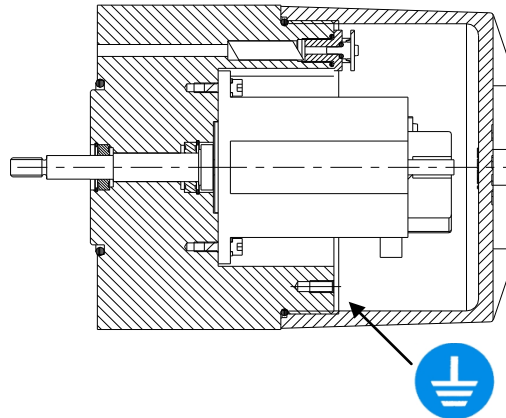

fig. 3 - Internal ground connection

- The actuator must be installed and used according to the project design specification.
- The fluid must be chemically compatible with the used gaskets and lubricant.
- The step motor must be used through the enclosed supplied controller STI ref. AD22255 (and relevant driver TRINAMIC model TCM-035).
- The supply circuits must be protect in case of current exceeding the limits fixed The user has to ensure prior to start up and during operation that the pressure transducers are correctly fixed inside the enclosure all the time.
- The rated values for pressure transducer must be guarantee.



1.2.2 Maintenance

- Must be done by qualified person who is trained to operate into potentially explosive atmosphere.
- Tools and equipment must be suitable for potentially explosive atmosphere where the actuator is installed.
- Cleaning must be done with a humid cloth.
- Greases and oils must be used according to the manufacturer's instructions, however their flammability point must be $> 140^{\circ}\text{C}$.

2. GENERAL FEATURES

The step-motor enclosure mod. DPS is composed by an enclosure in which a step-motor and 3 pressure transducers are installed and a cover. On the step-motor's shaft an extension shaft equipped with 2 rolling bearing is fitted.

O-ring gaskets between the enclosure and the cover and between the enclosure and the support columns are used in order to guarantee the protection degree of the enclosure.



INSTRUCTION MANUAL DPS (DIGITAL POSITION SYSTEM) QT series (motor)



TECHNICAL FEATURES

This device meets requirements for CE conformity certification (CEI EN55022, CEI EN 50082-2).

Ambient temperature :	-40° to +70°C
Step-motor electrical input parameters (with driver control): (POWERMAXII series M22NxxB)	- I _s (dc): 1.5A - V _s (dc): 40V
Step-motor mechanical output:	1 (360°) actuation/sec
Pressure transducer electrical / pneumatic features: (FUJIKURA model XFGM-3001MPGSR)	- I _{max} (dc): 10 mA - V _{max} (dc): 5V - P _{range} : 0÷10 bar
Encoder supply voltage :	5V
Driver electrical input parameters: (TRINAMIC model TCM-035)	- V _o (dc): 40V - I _o (dc): 3A
Conduit entries :	N°2 holes 3/4" NPT F

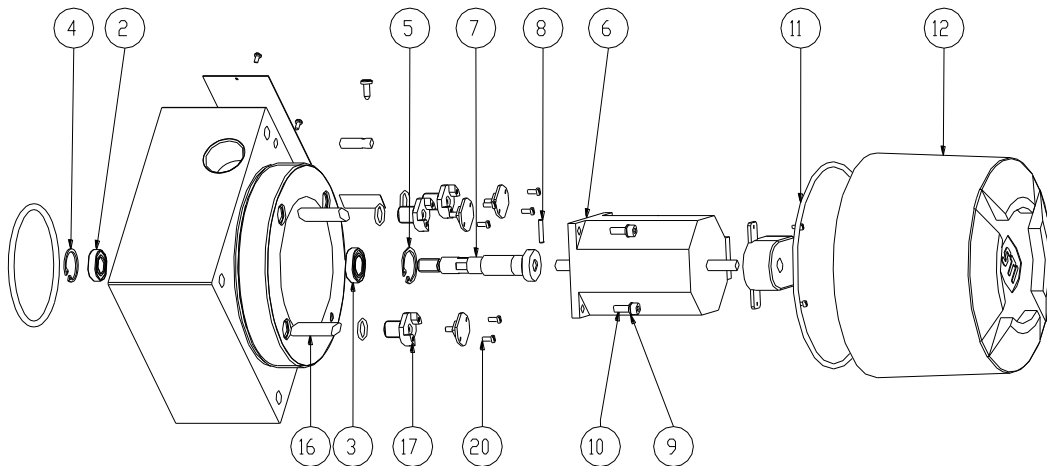

fig. 4 – Motor enclosure components

MATERIALS

Housing:	Aluminum UNI EN 9002/5
Cover [12]:	Aluminum G-Al Si 9 Mn Mg UNI 3051
Shaft extension [7] :	Stainless Steel AISI 303
Rolling bearing [3-2]:	Stainless steel
Column supports for pressure transducers [17]:	Aluminum UNI EN 9002/5
Flameproof joint [16]	Stainless Steel AISI 303

3. MOUNTING PROCEDURE

The step-motor is supplied with a stem extension pos.7 connected by a pin pos. 8 to its shaft.



Do not remove the pin pos. 8 for any reason.



For mounting or dismounting operation, follow these instructions (see above picture):

- mount rolling bearing pos. 2 in its appropriate seat and then clip pos. 4
- mount rolling bearing pos. 3 in its appropriate seat and then clip pos. 5
- insert step-motor pos. 6 inside the enclosure, taking care not to make an excessive axial force on the step-motor's shaft; fix the step-motor to the enclosure by the 4 screws pos. 9-10
- insert N°3 flame proof joint pos. 16 inside the corresponding holes
- mount N°3 O-rings and screw the pressure transducers support columns pos. 17 inside the corresponding holes.
- mount O-ring pos. 11
- screw the cover pos. 12

For the cables wiring refer to relevant electric diagram

4. MAINTENANCE OPERATION



No maintenance operations are required on the stepping motor. In case of abnormal noise or malfunction contact STI.

Information in this manual is protected by copyright. All rights are reserved. No part of this manual and relevant mentioned and/or enclosed documentation may be reproduced without written authorization by **STI S.r.l.**

STI S.r.l. is not responsible for possible damage to people, equipment or data which might arise from incorrect use of the product to which the manual is referred.

Information in this document may be modified at any time without notice.